



Ultra-Reliable MPC564xA MCU for Automotive and Industrial Engine Management

MPC564xA

Last Updated: May 30, 2023

The MPC564xA family of MCUs offers enhanced powertrain functionality and addresses the harsh environments of mid-range gasoline and direct injection engines, advanced transmissions, and industrial applications.

- Designed to help lower overall system costs
- Offers higher performance than single-issue cores at the same frequency
- Operates at low power for high-temperature environments, such as transmissions
- Enables precision tuning to optimize fuel economy and reduce emissions
- Improves shift control

MPC564xA Block Diagram Block Diagram

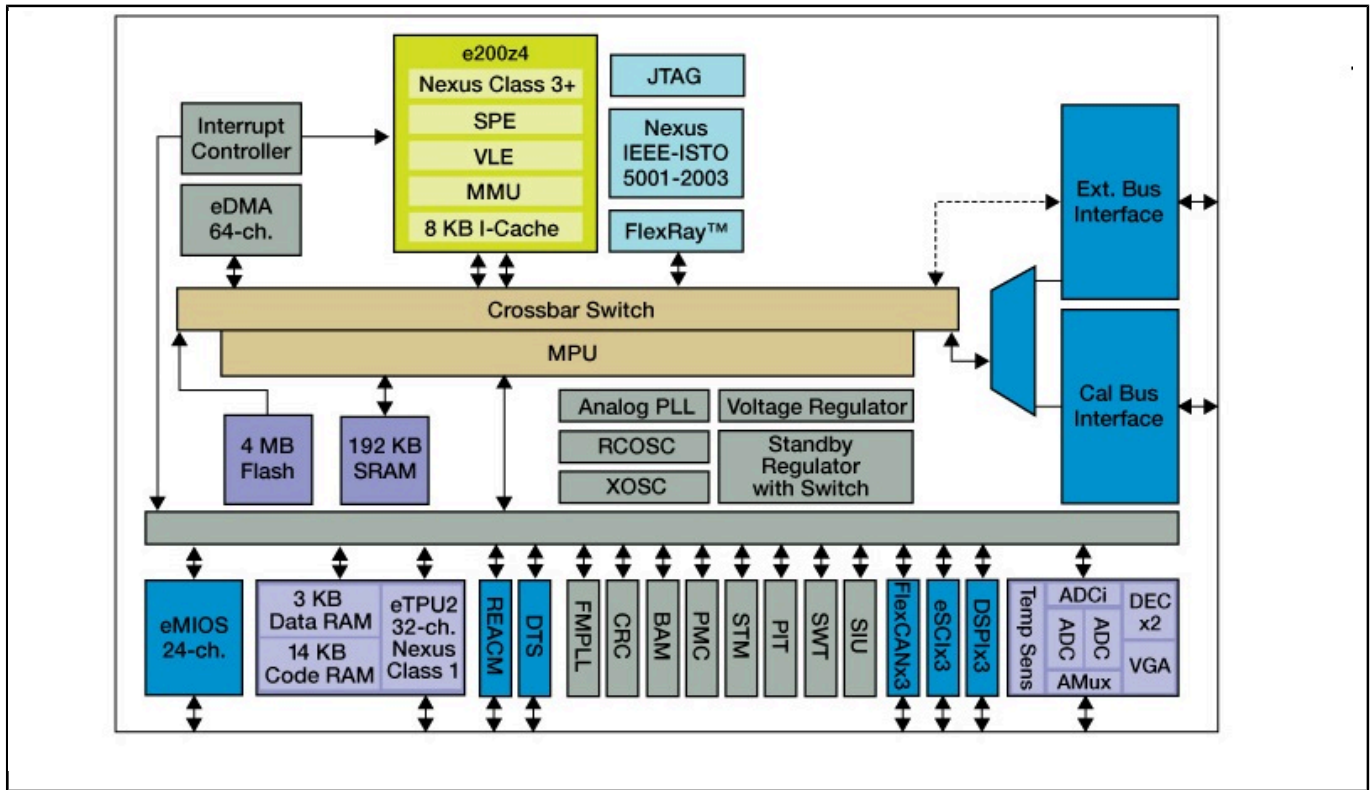

View additional information for [Ultra-Reliable MPC564xA MCU for Automotive and Industrial Engine Management](#).

Note: The information on this document is subject to change without notice.

www.nxp.com

NXP and the NXP logo are trademarks of NXP B.V. All other product or service names are the property of their respective owners. The related technology may be protected by any or all of patents, copyrights, designs and trade secrets. All rights reserved. © 2024 NXP B.V.