



USB PD and Type-C Current-Limited Power Switch

NX5P3090UK

Last Updated: Jun 7, 2022

The NX5P3090 is a precision adjustable current-limited power switch for USB PD application. The device includes under voltage lockout, over-temperature protection, and reverse current protection circuits to automatically isolate the switch terminals when a fault condition occurs. The 29V tolerance on VBUS pin ensures the device is able to work on a USB PD port; a current limit input (ILIM) pin defines the over-current limit threshold; an open-drain fault output (FAULT) indicates when a fault condition has occurred.

The over-current limit threshold can be programmed from 400 mA to 3.3 A, using an external resistor between the ILIM pin and GND pin. In the over current condition, the device will clamp the output current to the value set by ILIM and keep the switch on while assert the FAULT flag. To minimize current surges during turn on and turn off, the device has built in soft start which controls the power switch rise and fall time.

Surge protection has been integrated in the device to enhance system robustness. The enable input includes integrated logic level translation making the device compatible with lower voltage processors and controllers.

NX5P3090 is offered in a 12 bump 1.35 × 1.65 mm, 0.4 mm pitch WLCSP package.

NX5P3090 Block Diagram Block Diagram

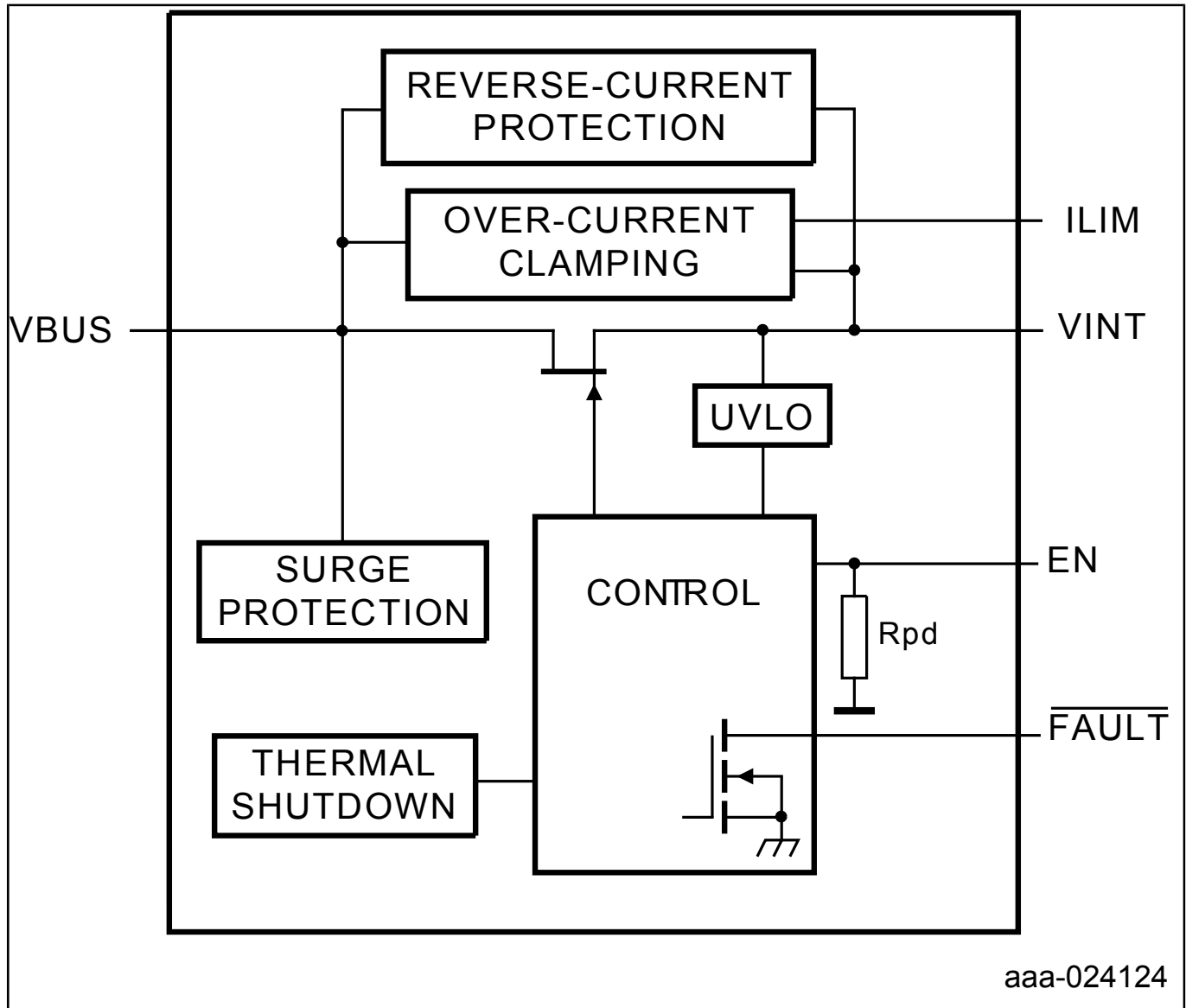

View additional information for [USB PD and Type-C Current-Limited Power Switch](#).

Note: The information on this document is subject to change without notice.

www.nxp.com

NXP and the NXP logo are trademarks of NXP B.V. All other product or service names are the property of their respective owners. The related technology may be protected by any or all of patents, copyrights, designs and trade secrets. All rights reserved. © 2024 NXP B.V.