



Tiny Real-Time Clock/Calendar with Alarm Function, Battery Switch-Over, Time Stamp Input and I²C-Bus

PCF85263A

Last Updated: Mar 19, 2024

The PCF85263A is a CMOS Real-Time Clock (RTC) and calendar optimized for low power consumption and with automatic switching to battery on main power loss. The RTC can also be configured as a stop-watch (elapsed time counter). Three time log registers triggered from battery switch-over as well as input driven events. Featuring clock output and two independent interrupt signals, two alarms, I²C interface and quartz crystal calibration.

PCF85263A Block Diagram Block Diagram

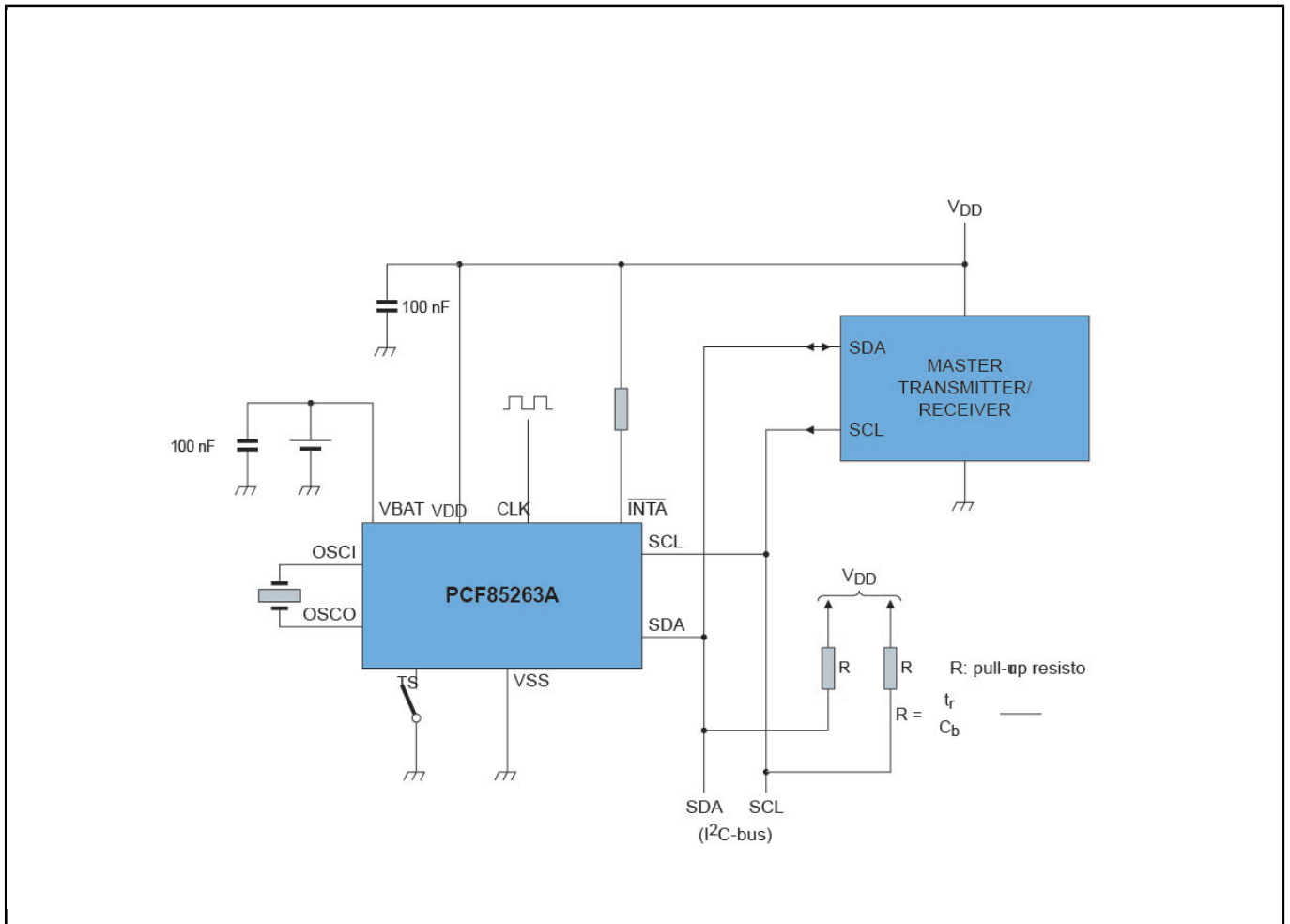

PCF85263A Application Diagram Block Diagram

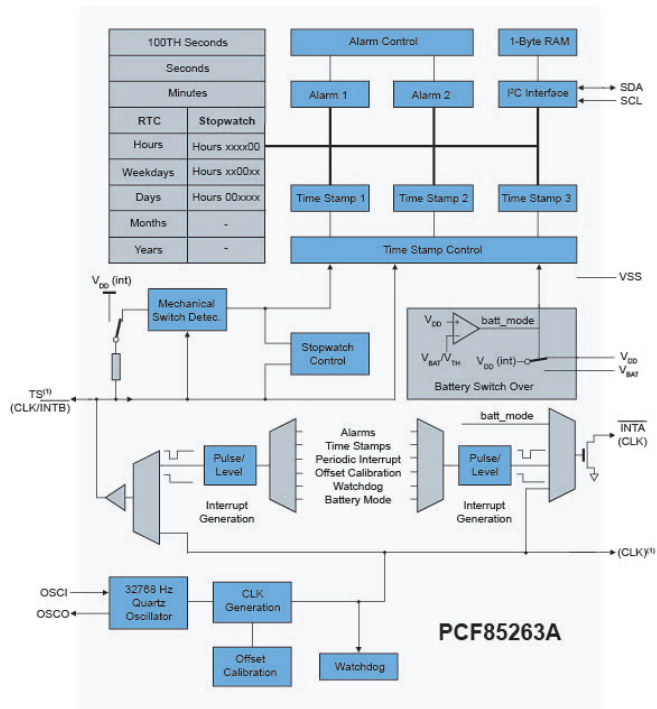

View additional information for [Tiny Real-Time Clock/Calendar with Alarm Function, Battery Switch-Over, Time Stamp Input and I²C-Bus](#).

Note: The information on this document is subject to change without notice.

www.nxp.com

NXP and the NXP logo are trademarks of NXP B.V. All other product or service names are the property of their respective owners. The related technology may be protected by any or all of patents, copyrights, designs and trade secrets. All rights reserved. © 2024 NXP B.V.