



# Programmable Solenoid Controller Gate Driver

## PT2000

Last Updated: Apr 19, 2024

The PT2000 programmable gate driver for solenoid control integrates six microcores, seven external MOSFET high-side pre-drivers, and eight external MOSFET low-side pre-drivers. Two low-side drivers can be used as DC/DC converters. Microcores allows six parallel tasks to run independently from the main system microcontroller (MCU). The PT2000 also included diagnostics, automatic DC/DC control, current measurement and end of injection detection.

# PT2000: 8-Channel Programmable Solenoid Controller Gate Driver Block Diagram

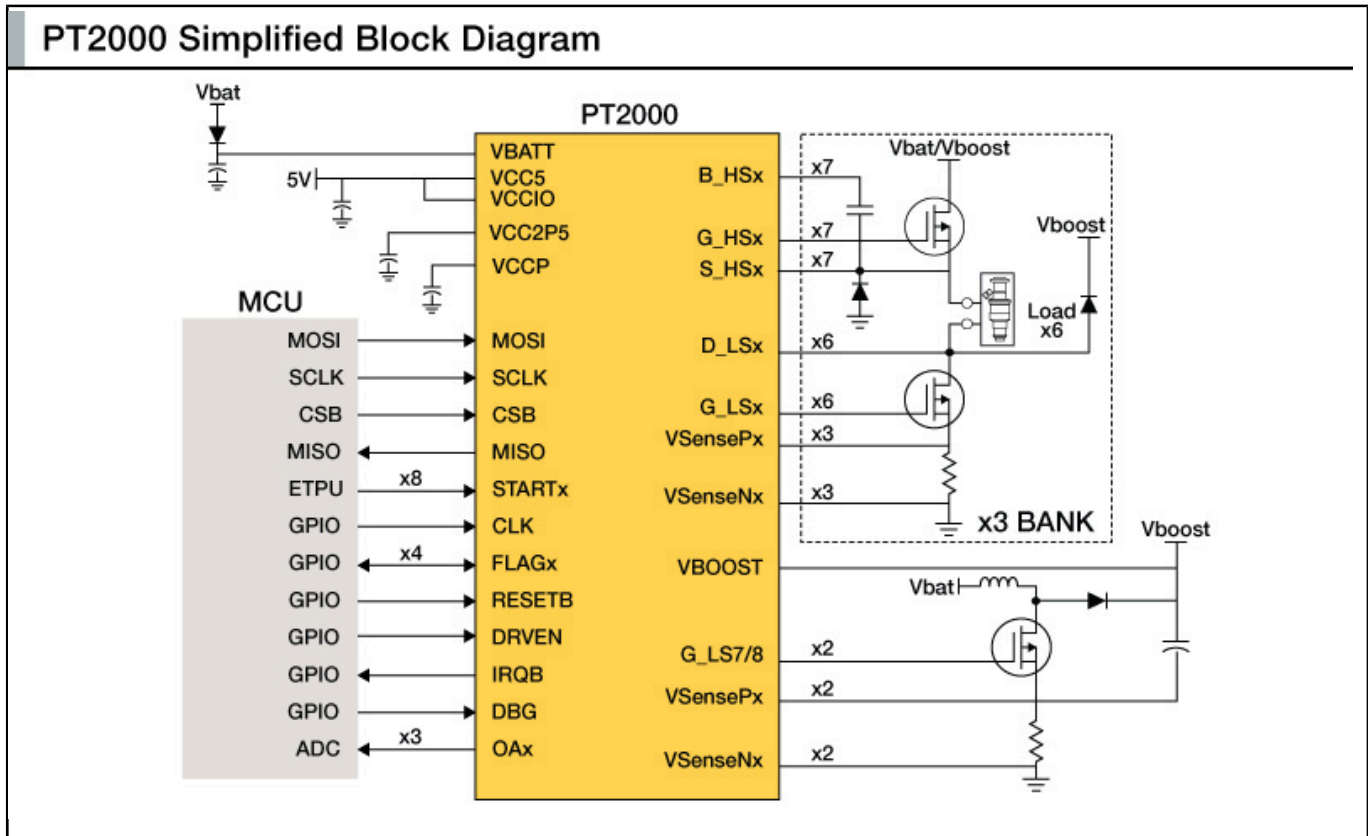

View additional information for [Programmable Solenoid Controller Gate Driver](#).

Note: The information on this document is subject to change without notice.

[www.nxp.com](http://www.nxp.com)

NXP and the NXP logo are trademarks of NXP B.V. All other product or service names are the property of their respective owners. The related technology may be protected by any or all of patents, copyrights, designs and trade secrets. All rights reserved. © 2024 NXP B.V.