



LIN Transceiver with Integrated Voltage Regulator

TJA1028

Last Updated: May 16, 2024

The TJA1028 is a LIN 2.0/2.1/SAE J2602 and ISO 17987-4:2016 (12 V) compliant transceiver with an integrated low-drop voltage regulator.

The voltage regulator can deliver up to 70 mA and is available in 3.3 V and 5.0 V variants. TJA1028 facilitates the development of compact nodes in local interconnect network (LIN) bus systems. To support robust designs, the TJA1028 offers strong electrostatic discharge (ESD) performance and can withstand high voltages on the LIN bus.

In order to minimize current consumption, the TJA1028 supports a Sleep mode in which the LIN transceiver and the voltage regulator are powered down while still having wake-up capability via the LIN bus.

The TJA1028 comes in an SO8 package, and also in a 3 mm × 3 mm HVSON8 package that reduces the required board space by over 70 %. This feature can prove extremely valuable when board space is limited.

TJA1028 Block Diagram Block Diagram

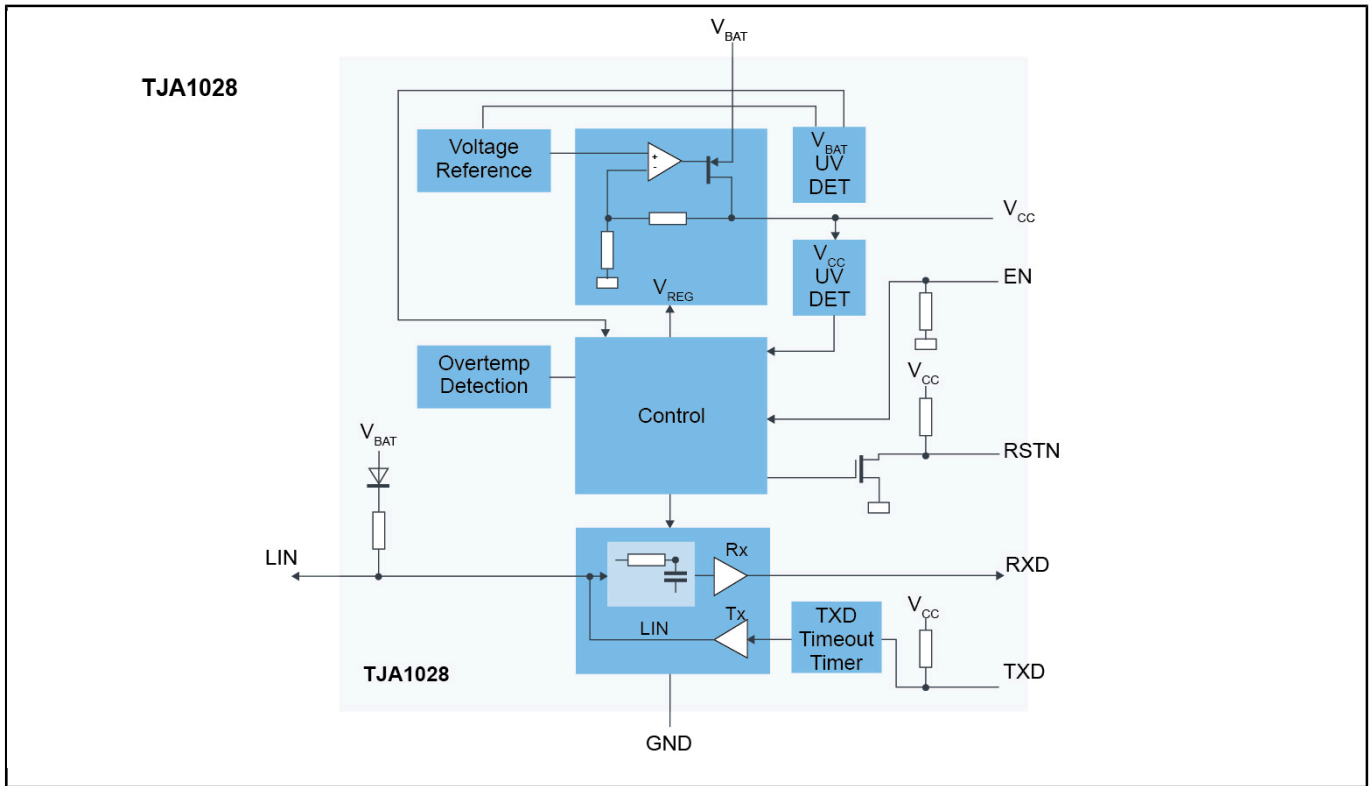

View additional information for [LIN Transceiver with Integrated Voltage Regulator](#).

Note: The information on this document is subject to change without notice.

www.nxp.com

NXP and the NXP logo are trademarks of NXP B.V. All other product or service names are the property of their respective owners. The related technology may be protected by any or all of patents, copyrights, designs and trade secrets. All rights reserved. © 2024 NXP B.V.