



High-Speed CAN Transceiver with Standby Mode – Mantis Family

TJA1044

Last Updated: May 16, 2024

For security on TJA1042, TJA1044, TJA1049, go to [Secure CAN TJA1152](#), for higher data rates on these devices, go to [CAN SIC TJA1462](#).

The TJA1044 is part of the Mantis family of high-speed CAN transceivers. It provides an interface between a controller area network (CAN) protocol controller and the physical two-wire CAN bus. The transceiver is designed for high-speed CAN applications in the automotive industry, providing the differential transmit and receive capability to (a microcontroller with) a CAN protocol controller. Ideal passive behavior to the CAN bus when the supply voltage is off.

A very low-current Standby mode with bus wake-up capability Excellent EMC performance, even without a common mode choke. Variants with a VIO pin can be interfaced directly with microcontrollers with supply voltages from 3.3 V to 5 V

These features make the TJA1044 an excellent choice for all types of HS-CAN networks, in nodes that require a low-power mode with wake-up capability via the CAN bus.

The TJA1044 implements the CAN physical layer as defined in the current 11898-2:2016 and SAE J2284-1 to SAE J2284-5. The TJA1044T is specified for data rates up to 1 Mbit/s. Additional timing parameters defining loop delay symmetry are specified for the other variants. This implementation enables reliable communication in the CAN FD fast phase at data rates up to 5 Mbit/s.

TJA1044 Block Diagram

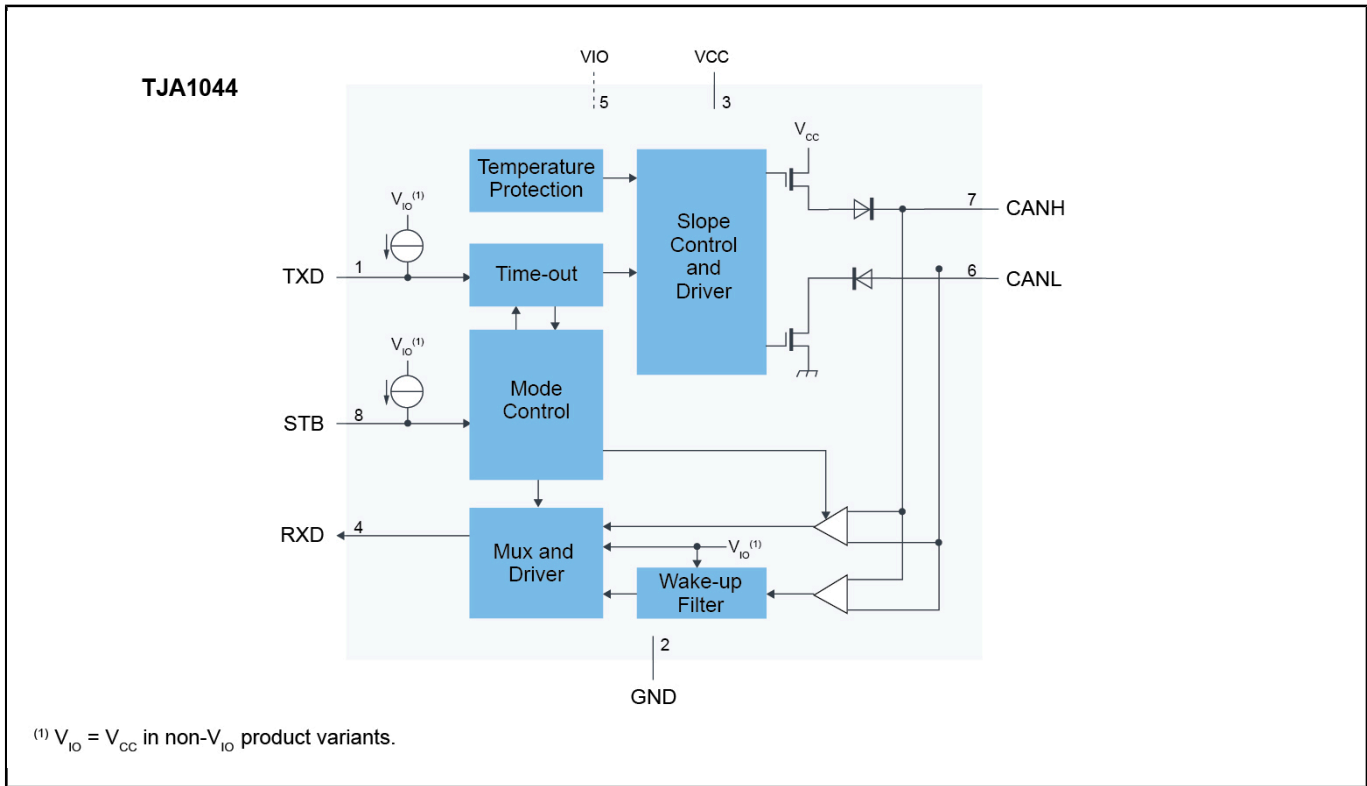

View additional information for [High-Speed CAN Transceiver with Standby Mode - Mantis Family](#).

Note: The information on this document is subject to change without notice.

www.nxp.com

NXP and the NXP logo are trademarks of NXP B.V. All other product or service names are the property of their respective owners. The related technology may be protected by any or all of patents, copyrights, designs and trade secrets. All rights reserved. © 2024 NXP B.V.