



FlexRay Active Star Coupler – 4 Branch

TJA1085G

Last Updated: Mar 18, 2024

The TJA1085G is a FlexRay active star coupler that can connect up to 4 branches of a FlexRay network. The TJA1085G is compliant with the FlexRay electrical physical layer specification V3.0.1/ISO17458-4

Several TJA1085G devices can be connected via their TRXD0/1 interfaces to increase the number of branches in the network. A dedicated Communication Controller (CC) interface allows for integration into an ECU. The TJA1085G supports low-power management by offering bus wake-up capability along with battery supply and voltage regulator control. The TJA1085G meets industry standards for EMC/ESD performance and provides enhanced bus error detection, low current consumption and unmatched asymmetric delay performance.

TJA1085G Block Diagram Block Diagram

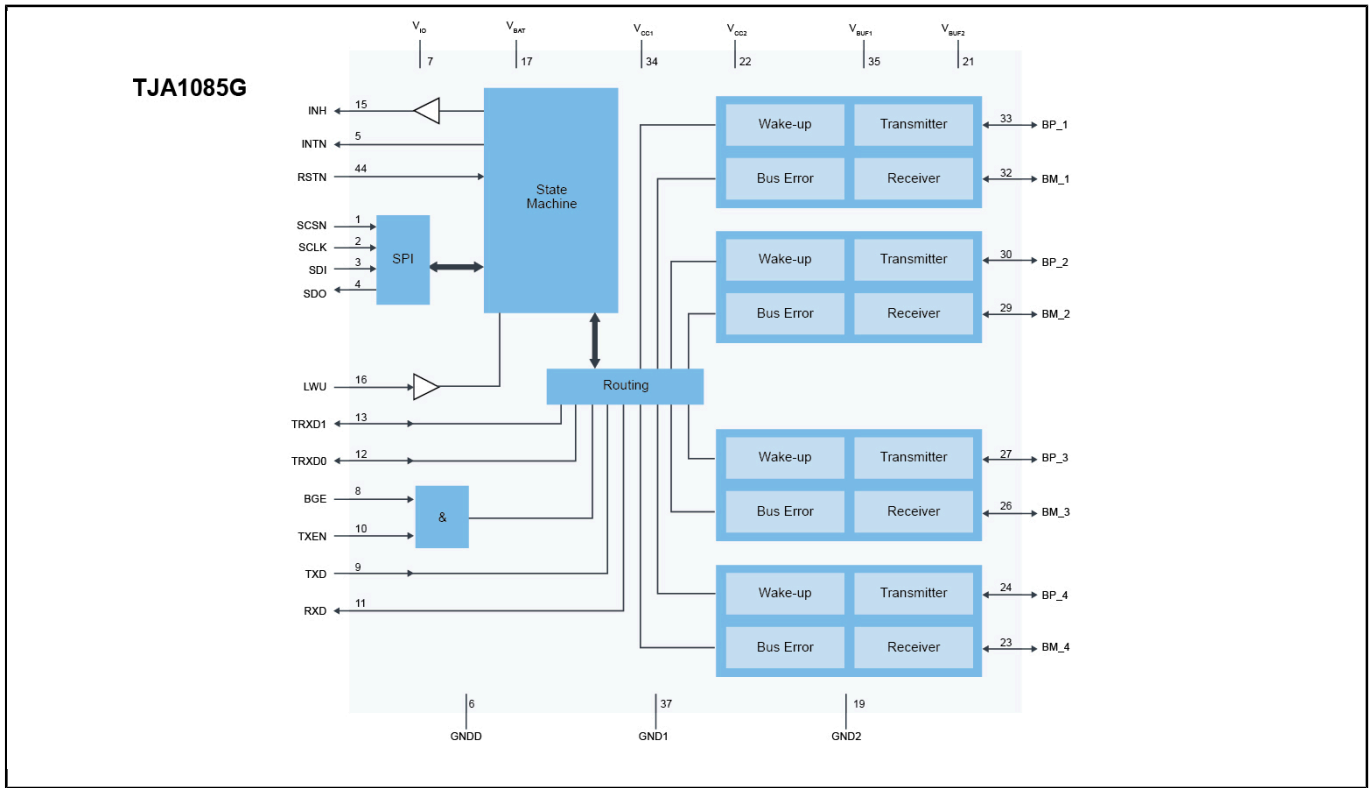

View additional information for [FlexRay Active Star Coupler – 4 Branch](#).

Note: The information on this document is subject to change without notice.

www.nxp.com

NXP and the NXP logo are trademarks of NXP B.V. All other product or service names are the property of their respective owners. The related technology may be protected by any or all of patents, copyrights, designs and trade secrets. All rights reserved. © 2024 NXP B.V.