

# Production Flash Programming for the 56F8000 Family

Techniques for Production Programming the 56F8000 Family of Devices, Flash Memory Blocks

*Leonard N. Elevich*

## 1. Introduction

This document presents techniques and detailed information on production programming of the Program Flash memory blocks in the 56F8000 components. This is distinct from the developmental loading of the Flash blocks that is achieved using developmental tools such as the Metrowerks CodeWarrior for Freescale debugger.

There are four ways to program the Flash blocks in a factory environment:

- Using the Serial Bootloader present in the Internal Flash
- Using a commercially-available device programmer
- Using the JTAG/OnCE™ port
- Using GPIO pins with a custom bootloader

The first two methods do not require any developmental effort to use. Using the GPIO pins to obtain the Flash programming data would require the customer to develop his own loader program.

## 2. Background Information

As a starting point, all methods require an application to be created using the CodeWarrior development tools. This application must be specifically targeted to operate correctly from the internal Flash. The Freescale CodeWarrior Development tools includes information as well as code to aid

## Contents

1. Introduction .....	1
2. Background Information .....	1
2.1 Considerations for Choosing a Production Programming Method ...	2
3. Programming Method Details .....	3
3.1 Serial SCI Bootloader .....	3
3.2 Bulk Device Loader .....	3
3.3 In-circuit JTAG/OnCE Port .....	4
3.4 GPIO Flash Programming Mode ....	5
4. Conclusion .....	6
5. References .....	6

in the development of the application. It is highly recommended that a developer start with the appropriate Processor Expert (PE) stationery. This will greatly facilitate the development of the application, and includes all the elements required to create embedded applications targeting internal Flash. During development and debug of the application, the CodeWarrior tool can be used to program the internal Flash and to debug the program while running from Flash. Once the development and test are complete, the CodeWarrior tool can also be used to generate the source file containing the executable image of the Program Flash block. In this case, the source file is an S-record file. The S-record file contains the hex machine code and hex data information formatted in a text file containing a series of S3-type S-records. Refer to [Appendix A](#) at the end of this document for a detailed description of the format of the S-record file.

The CodeWarrior tool normally uses *.elf* files to store the application executable and to program the Flash blocks in the devices. The user must specifically configure the CodeWarrior tool to create the S-record file. Please refer to the **CodeWarrior Targeting 56800E Manual** for information on how to turn on S-record generation. The CodeWarrior tool generates three separate types of S-record files:

- *output\_filename.p.S* contains the Program Flash image
- *output\_filename.x.S* contains the Data Flash image
- *output\_filename.S* contains the combined Program and Data Flash images

The S-record file is the source file used by first two methods of production Flash programming. The file to use when performing Flash programming will generally be the combined file, containing the Program and Data Flash image. Please note that while 56F8000 devices do not have Data Flash, it is still recommended to use combined S-record file.

## 2.1 Considerations for Choosing a Production Programming Method

A fundamental decision to be made is whether to initially program the devices after they have been soldered to the circuit board, or to initially program the devices before they are placed onto the circuit board. Programming with the Boot Flash Serial Bootloader, programming via the JTAG/OnCE port and the GPIO Flash programming mode are primarily intended as in-circuit programming methods. The bulk device load method is an out-of-circuit programming method, which allows programming the 56F8000 devices in advance of the production run.

Since the JTAG/OnCE port and the bulk device loader mode options do not require that software be run from any of the Flash blocks, they can reprogram any block without special considerations. The 56F8000 chips are fully field reprogrammable, requiring no special voltages or external hardware to perform this function.

There is another option to consider. All of the 56F8000 devices also contain on-chip program RAM. A bootloader can be loaded into this RAM and, from there, all Flash blocks can be reprogrammed.

All in-circuit Flash loading methods require that the target hardware conforms to certain minimal standards. For the Serial Bootloader, these standards require that:

- The SCI port must be accessible for serial communications

Using the JTAG/OnCE port method requires only that a subset of the JTAG/OnCE pins be made available. Please refer to [Section 3.3](#) for details.

Using the GPIO port method would require access to any user-specified GPIO pins that the user-defined bootloader software specified.

The approximate speeds at which the Flash blocks can be programmed with the various methods are:

- **SCI Serial Bootloader** = 2.5K words per second
- **Bulk device programmer** = 3K words per second
- **In-circuit JTAG/OnCE port** = 3K words per second.

## 3. Programming Method Details

### 3.1 Serial SCI Bootloader

The software and protocol for this loader and how to use it are fully described in the Metrowerks on-line help and web site (see [References](#)). Please refer to the SCI Bootloader application information in the **56F801x Serial Bootloader User Guide** for the processor being used. This manual has detailed information on how to use the Serial Bootloader and how to prepare your application for loading using the Serial Bootloader.

**Table 3-1. Details of SCI Serial Bootloader Versions 1.2**

Version	Baud Rate	Flow Control	Word Format
1.2	115,200bps	Xon/Xoff	8 data bits, no parity, 1 stop bit

**Figure 3-1** shows a possible hardware configuration for using the Serial Bootloader to program the device in-circuit. This is one of many possible hardware configurations that will support the use of the Serial Bootloader to program the device.

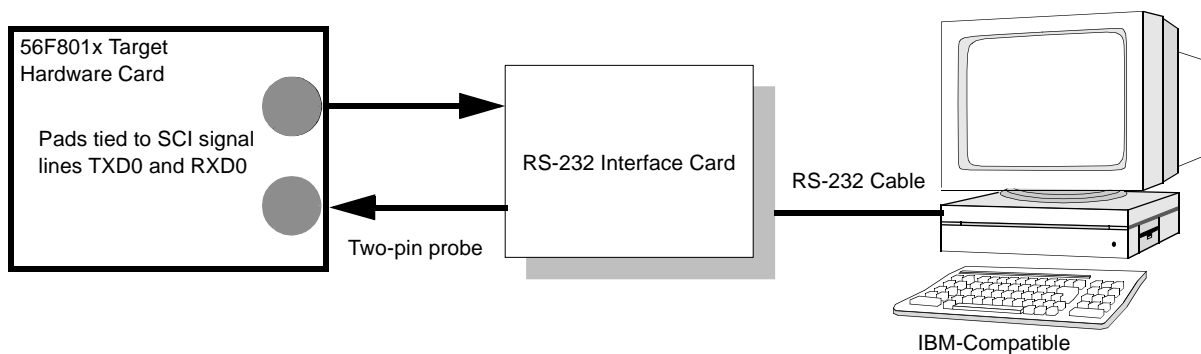

**Figure 3-1. One Hardware Configuration for SCI Serial Bootloader**

The configuration in **Figure 3-1** shows how the Serial Bootloader can be used, even though the target hardware has no additional connectors or RS-232 serial drivers. In addition, using an IBM-compatible computer is not required--any host capable of providing the required serial stream and the protocol can be used.

### 3.2 Bulk Device Loader

In this method, the devices are programmed out-of-circuit in a device loader. The programming can be performed using your own resources, or possibly through your distributor or another value-added reseller. The device programmer can also be used to program the Program Flash blocks. The device programmer can be used to load a complete and final application, or simply a custom Bootloader program. Later, the final or complete application can be loaded using the custom Bootloader.

Please check [www.freescale.com/dsc](http://www.freescale.com/dsc) for device programmers support.

### 3.3 In-circuit JTAG/OnCE Port

To use this method, the user must provide access from his host computer to the JTAG/OnCE port signals on the devices. [Table 3-2](#) shows the required signals. If the programming set-up uses a standard command converter to interface to the JTAG signals, then a standard JTAG pin header connector must be present on the custom card. An example of this is present on the MC56F8013DEMO board; information on it is also included in the [56F8013 Demonstration Board User Guide](#), which can be downloaded from Freescale's website at: <http://www.freescale.com/dsc>.

**Table 3-2. Required JTAG/OnCE Signals**

Signal	Signal Description	Required
TDI	<b>Test Data Input</b> —This input pin provides a serial input data stream to the TAP and the TLM. It is sampled on the rising edge of TCK. TDI has an on-chip pull-up resistor which can be disabled through SIM_PUDR register in the SIM module.	Yes
TDO	<b>Test Data Output</b> —This tri-state output pin provides a serial output data stream from the Master TAP, or 56800E core TAP Controller. It is driven in the Shift-IR and Shift-DR controller states of the TAP Controller state machines. Output data changes on the falling edge of TCK.	Yes
TCK	<b>Test Clock Input</b> —This input pin provides the clock to synchronize the test logic and shift serial data to and from all TAP Controllers and the TLM. If the EOnCE module is not being accessed using the Master or 56800E core TAP Controllers, the maximum TCK frequency is 1/4 the maximum frequency for the 56800E core. When accessing the EOnCE module through the 56800E core TAP Controller, the maximum frequency for TCK is 1/8 the maximum frequency for the 56800E core. The TCK pin has a pull down non-disabled resistor.	Yes
TMS	<b>Test Mode Select Input</b> —This input pin is used to sequence the TAP Controller's TLM state machine. It is sampled on the rising edge of TCK. TMS has an on-chip pull-up resistor which can be disabled through SIM_PUDR register in the SIM module.	Yes
$\overline{\text{TRST}}$	<b>Test Reset</b> —This input pin provides an asynchronous reset signal to the TLM and all TAP Controllers. If the JTAG is not going to be used, prevent signal interference by holding it low during operation.	Yes

The CodeWarrior tool, which supports command line interface as well as scripting, can be used to download the program in production environment. The following steps must be performed to prepare for production flash programming:

- Install CodeWarrior Development tools on IBM-compatible machine that will be used in production environment
- Obtain and install free 8K Words license key to enable CodeWarrior functionality
- Compile project containing final application on the development machine.
- Copy all project files except source code from the development machine to production machine.

- Open CodeWarrior IDE on production machine and select Edit/Preferences menu
- Set “Building before running” to “Never” in the “Build Settings” panel
- Click “OK” button to save changes.
- Create a CodeWarrior TCL script file that will load application project into flash via CodeWarrior debugger. **Example 3-1** provides example of this script file named test.tcl In this example, script will load an application project named script1.mcp located in D:\tmp\cw\_script1 directory
- Create a batch file that will execute this TCL script from the command line. **Example 3-2** provides example of this batch file named test.bat. In this example batch file will execute test.tcl script located in D:\tmp\cw\_script1 directory. Please note that path to cmdide.exe may need to be modified to reflect your actual CodeWarrior installation directory.

---

**Code Example 3-1. Example TCL file test.tcl**

---

```
debug d:/temp/cw_script1/script1.mcp
go nowait
kill
```

---

**Code Example 3-2. Example Batch file test.bat**

---

```
"d:\program files\metrowerks\codewarrior 7.2\bin\cmdide.exe" /d
d:\temp\cw_script1\test.tcl
```

Once above preparation steps are completed, production technician can program Flash simply by executing created batch file.

Detailed information on how to program using the JTAG/OnCE port is available and can be requested from your Freescale sales representative.

### 3.4 GPIO Flash Programming Mode

This mode requires the customer to define his own definition of GPIO Flash programming pin definitions and code load protocol. He would then have to develop an appropriate bootloader application to program into the Boot Flash. This approach would also require the customer to provide access to the required pins for his program loading.

## 4. Conclusion

The 56F810x components are very flexible in programming Flash blocks. In this application note, several methods have been presented for programming the Flash blocks in a production environment. One of these methods, or a variation of it, should meet your production Flash programming requirements.

## 5. References

The following materials were used to produce this paper:

1. *CodeWarrior IDE Targeting 56F8300 Manual*  
*CodeWarrior for Freescale DSP56800E Embedded Systems, CWDSP56800E*
2. *Targeting Freescale 56F8300 Platform, Processor Expert*  
*CodeWarrior™ Development Studio for 56800/E Hybrid Controllers with Processor Expert, CW568x*
3. *56F801x Evaluation Module Hardware User Manual* for the device being implemented
4. *56F801x Serial Bootloader User Guide, MC56F801xBLUG*
5. *Programming On-Chip Flash Memories of DSP56F80x DSPs using the JTAG/OnCE Interface, AN1935*
6. Metrowerks help:  
**[www.metrowerks.com/MW/support](http://www.metrowerks.com/MW/support)**  
or  
**[support@metrowerks.com](mailto:support@metrowerks.com)**

# Appendix A S-Record Specification

*Note: All references to Data Flash in the appendix apply only to the 56F8300 family of devices; the 56F8100 devices do not support Data Flash.*

- 1) Use only S0, S3 and S7 records
- 2) Three S-Record files are built with every compile. The first contains the contents of all initialized PROGRAM (P) Memory contents. The second file contains the contents of all initialized DATA (X) Memory contents.
- 3) The third S-Record file (the “combined” file) is roughly a concatenation of the P file with the X file (P followed by X). The S3 data records targeted for X shall have an offset of 0x02000000 added to their byte address fields. There shall be only a single pair of S0 and S7 records for the entire combined file.

## Notes:

- The P (and combined) file may contain: Program Flash contents, Program RAM contents, Boot Flash contents
  - The X (and combined) file may contain: Data Flash contents, Data Ram contents
  - The device programming algorithm shall be address range aware
    - a) The byte address fields of S3 data records are examined by the device programming algorithm to determine which Flash memory to access
    - b) The offset of 0x02000000 for X data records is required because the P and X memories within the 56F8300 devices both start at address 0. (S-Records don't normally support overlapping memories; defining an offset is the most expedient work-around for the problem.)
    - c) Data specified for RAM locations shall be ignored by the device programming algorithm.
- 4) Unique codes shall reside in the P, X and combined S0 header records. In this manner, the S0 records will identify the subsequent contents as either P, or X, or combined. The proposed S0 header records are as follows:

### Code Example A-1. S0 Record for the P File

---

```
S0 0C 00000000 50 52 4F 47 52 41 4D DB
(Hex ASCII for: P R O G R A M )
```

### Code Example A-2. S0 Record for the X File

---

```
S0 09 00000000 44 41 54 41 DC
(Hex ASCII for: D A T A )
```

### Code Example A-3. S0 Record for the Combined File

---

```
S0 11 00000000 50 52 4F 47 52 41 4D 26 44 41 54 41 96
```

(Hex ASCII for: P R O G R A M & D A T A)

**Notes:** The device programming algorithm will not be expected to recognize contents within any S0 record. The S0 content is only to aid with human recognition of file contents and to assist in content recognition by future tools.

5) S3 data shall not split across a processor word size (16 bits). In other words, there shall be an even number of “data” bytes within each S3 record.

Sample S-Record files for the 56F8300 and 56F8100 follow. (Spaces have been inserted for improved readability in this document; “CS” is a space holder for the checksum byte.) The address fields of the S3 record shall be conventional BYTE addresses and byte data shall be represented in the Little-endian format. (The Least Significant Byte [LSB] is located at the lowest address.)

**Notes:**

- In this manner, the constituent P or X S-Record files can be used to program any conventional (external) non-volatile memory devices, without the need for any additional S-Record manipulation utility programs
- 56F8300 and 56F8100 processors have a native 16 bit word. Likewise, the Flash memories are programmed with 16-bit words and all addresses are interpreted as word addresses
- To get from the S-Record Byte address to the 56F8300 and 56F8100 16-bit Word address, divide the S-Record address field value by 2. For X memory, first subtract the 0x02000000 offset, then unscramble the little-endian format to recognize the data words.

### Code Example A-4. Sample P File

---

S0 0C 00000000 50 52 4F 47 52 41 4D DB	"PROGRAM"
S3 0D 00000000 10 32 11 32 12 32 13 32 CS	
S3 0D 00000008 14 32 15 32 16 32 17 32 CS	
S3 0D 00000010 18 32 19 32 1A 32 1B 32 CS	
S3 0D 00040000 10 B2 11 B2 12 B2 13 B2 CS	Boot Flash starts at word
S3 0D 00040008 14 B2 15 B2 16 B2 17 B2 CS	address 20000
S7 05 00000000 CS	(byte address 40000)



**Code Example A-5. Sample X File**

---

```
S0 09 00000000 44 41 54 41 DC
S3 0D 00002000 10 A2 11 A2 12 A2 13 A2 CS
S3 0D 00002008 14 A2 15 A2 16 A2 17 A2 CS
S7 05 00000000 CS
```

"DATA"

**Note:** There is no offset used in the stand-alone X S-Record file.

In this example, word address 1000 is the first location to be programmed.

**Code Example A-6. Sample Combined File**

---

```
S0 11 00000000 50 52 4F 47 52 41 4D 26 44 41 54 41 96
S3 0D 00000000 10 32 11 32 12 32 13 32 CS
S3 0D 00000008 14 32 15 32 16 32 17 32 CS
S3 0D 00000010 18 32 19 32 1A 32 1B 32 CS
S3 0D 00040000 10 B2 11 B2 12 B2 13 B2 CS
S3 0D 00040008 14 B2 15 B2 16 B2 17 B2 CS

S3 0D 02002000 10 A2 11 A2 12 A2 13 A2 CS
S3 0D 02002008 14 A2 15 A2 16 A2 17 A2 CS
S7 05 00000000 CS
```

"PROGRAM  
& DATA"

Boot Flash starts at word address 20000

Big offset of 0x02000000 signifies X data follows

**S-Record Explanation**

S0 05 00000000 (data) CS

S0	S0 is a header record
S3	S3 is data
S7	S7 terminator for block of S3
05	(hex) 5 bytes follow
00000000	32 bits of byte addresses
CS	The Least Significant Byte (LSB) of the one's complement of the sum of the values represented in the pairs of characters making up the record length, address, and the data fields

After programming the 56F8300 or 56F8100 with either the combined file or both stand-alone P and X files, a debugger dump would yield results like those in the following Code Examples:

#### **Code Example A-7. Dump of Program (P) Flash**

---

```
address p:00 0000 = 3210
address p:00 0001 = 3211
address p:00 0002 = 3212
address p:00 0003 = 3213
address p:00 0004 = 3214...
```

#### **Code Example A-8. Dump of Boot Flash**

---

```
address p:02 0000 = B210
address p:02 0001 = B211
address p:02 0002 = B212
address p:02 0003 = B213...
```

#### **Code Example A-9. Dump of Data (X) Flash**

---

```
address x:00 1000 = A210
address x:00 1001 = A211
address x:00 1002 = A212
address x:00 1003 = A213
address x:00 1004 = A214...
```





## **How to Reach Us:**

### **Home Page:**

www.freescale.com

### **E-mail:**

support@freescale.com

### **USA/Europe or Locations Not Listed:**

Freescale Semiconductor  
Technical Information Center, CH370  
1300 N. Alma School Road  
Chandler, Arizona 85224  
+1-800-521-6274 or +1-480-768-2130  
support@freescale.com

### **Europe, Middle East, and Africa:**

Freescale Halbleiter Deutschland GmbH  
Technical Information Center  
Schatzbogen 7  
81829 Muenchen, Germany  
+44 1296 380 456 (English)  
+46 8 52200080 (English)  
+49 89 92103 559 (German)  
+33 1 69 35 48 48 (French)  
support@freescale.com

### **Japan:**

Freescale Semiconductor Japan Ltd.  
Headquarters  
ARCO Tower 15F  
1-8-1, Shimo-Meguro, Meguro-ku,  
Tokyo 153-0064, Japan  
0120 191014 or +81 3 5437 9125  
support.japan@freescale.com

### **Asia/Pacific:**

Freescale Semiconductor Hong Kong Ltd.  
Technical Information Center  
2 Dai King Street  
Tai Po Industrial Estate  
Tai Po, N.T., Hong Kong  
+800 2666 8080  
support.asia@freescale.com

### **For Literature Requests Only:**

Freescale Semiconductor Literature Distribution Center  
P.O. Box 5405  
Denver, Colorado 80217  
1-800-441-2447 or 303-675-2140  
Fax: 303-675-2150  
LDCForFreescaleSemiconductor@hibbertgroup.com

Information in this document is provided solely to enable system and software implementers to use Freescale Semiconductor products. There are no express or implied copyright licenses granted hereunder to design or fabricate any integrated circuits or integrated circuits based on the information in this document.

Freescale Semiconductor reserves the right to make changes without further notice to any products herein. Freescale Semiconductor makes no warranty, representation or guarantee regarding the suitability of its products for any particular purpose, nor does Freescale Semiconductor assume any liability arising out of the application or use of any product or circuit, and specifically disclaims any and all liability, including without limitation consequential or incidental damages. "Typical" parameters that may be provided in Freescale Semiconductor data sheets and/or specifications can and do vary in different applications and actual performance may vary over time. All operating parameters, including "Typicals", must be validated for each customer application by customer's technical experts. Freescale Semiconductor does not convey any license under its patent rights nor the rights of others. Freescale Semiconductor products are not designed, intended, or authorized for use as components in systems intended for surgical implant into the body, or other applications intended to support or sustain life, or for any other application in which the failure of the Freescale Semiconductor product could create a situation where personal injury or death may occur. Should Buyer purchase or use Freescale Semiconductor products for any such unintended or unauthorized application, Buyer shall indemnify and hold Freescale Semiconductor and its officers, employees, subsidiaries, affiliates, and distributors harmless against all claims, costs, damages, and expenses, and reasonable attorney fees arising out of, directly or indirectly, any claim of personal injury or death associated with such unintended or unauthorized use, even if such claim alleges that Freescale Semiconductor was negligent regarding the design or manufacture of the part.



Freescale™ and the Freescale logo are trademarks of Freescale Semiconductor, Inc. All other product or service names are the property of their respective owners. This product incorporates SuperFlash® technology licensed from SST.

© Freescale Semiconductor, Inc. 2005. All rights reserved.

AN3118

Rev. 0  
8/2005