



Three-phase Sensorless BLDC Motor Control Kit with the Qorivva MPC5604P

by: Petr Konvicny
Rožnov pod Radhoštěm, Czech Republic

1 Introduction

This application note describes the design of a three-phase brushless DC (BLDC) motor control drive using a sensorless algorithm. The design is targeted at automotive applications. This cost-effective solution is based on the MPC5604P device, dedicated for automotive motor control.

The system is designed to drive a three-phase BLDC motor without a positional feedback sensor. Application features include:

- Three-phase BLDC sensorless speed control
- Back-EMF (BEMF) sensing
- Application control user interface using the FreeMASTER debugging tool
- Maximal motor current limitation

Contents

1	Introduction	1
2	System concept	2
3	BLDC sensorless control	2
3.1	Brushless DC motor	2
3.2	Principles of six-step BLDC motor control	3
3.3	States of BLDC drive	7
4	MPC5604P controller board configuration	8
4.1	FlexPWM	9
4.2	CTU	10
4.3	eTIMER	11
5	Software implementation	12
5.1	Introduction	12
5.2	Application flow	13
5.3	Speed evaluation and control	14
5.4	Zero-cross detection	16
5.5	Current limitation controller	16
5.6	State machine	16
5.7	Library functions	20
5.8	Setting the software parameters for a specific motor	20
6	FreeMASTER user interface	20
6.1	Application start	20
7	Conclusion	21
8	References	21
9	Revision history	22

2 System concept

The system is designed to drive a three-phase BLDC motor. The application meets the following performance specifications:

- Targeted at the MPC5604P microcontroller (refer to the dedicated reference manual for the MPC5604P, found at www.freescale.com)
- Running on the MPC5604P control drive board (refer to the dedicated user manual for the MPC5604P controller board)
- Control technique incorporating:
 - Sensorless control of a three-phase BLDC motor
 - Zero-crossing technique
 - Closed-loop speed control
 - Closed-loop current control
 - Starting up with alignment
 - BEMF voltage sensing
 - 50 μ s sampling period with the FreeMASTER recorder
- FreeMASTER software control interface (motor start/stop, speed set-up)
- FreeMASTER software monitor
- DC bus over-voltage, under-voltage, over-current, and overload protection

3 BLDC sensorless control

3.1 Brushless DC motor

The BLDC motor is a rotating electric machine with a classic three-phase stator. As in an induction motor, the rotor has surface-mounted permanent magnets. There are no brushes on the rotor and the commutation is performed electronically at a certain rotor position. The displacement of the magnets on the rotor creates a trapezoidal BEMF shape, which means that a DC voltage with a rectangular shape (see [Figure 1](#)) can be used to create a rotational field with low torque ripples. The motor can have more than one pole pair per phase. The pole pair per phase defines the ratio between the electrical revolution and the mechanical revolution. The rectangular shape of the applied voltage ensures the simplicity of control and drive. However, the rotor position must be known at certain angles in order to align the applied voltage with the BEMF. The best efficiency is achieved when BEMF and commutation events are aligned, in which case the motor behaves as a DC motor.

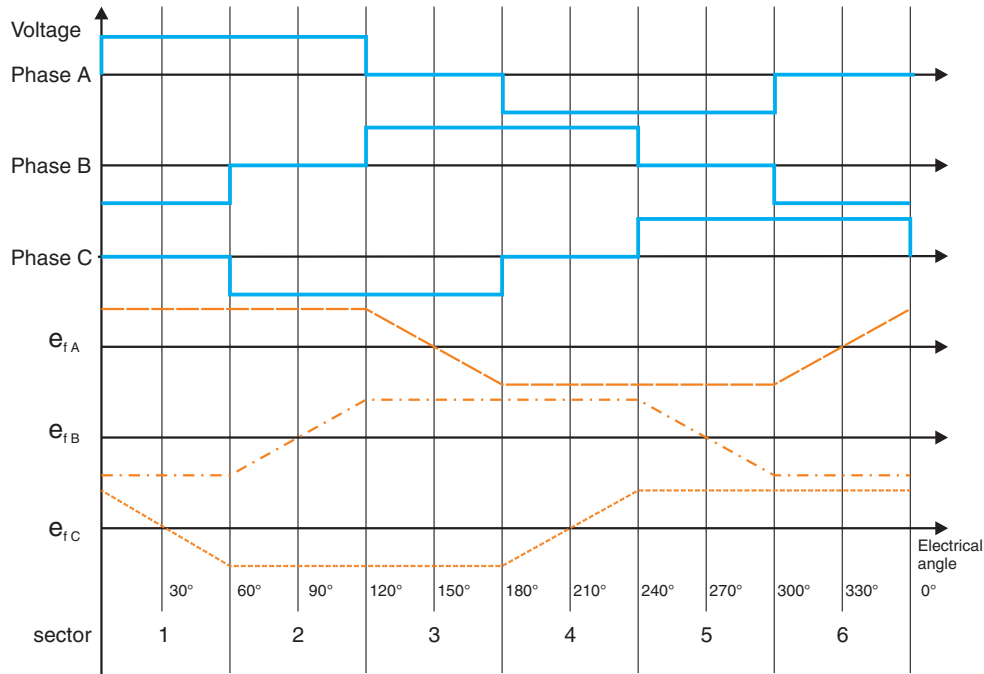

Figure 1. Three-phase voltage system for a BLDC motor

The main task for sensorless control of a BLDC motor is the estimation of rotor position. For rotor position estimation, this application uses a technique based on BEMF sensing.

- Speed range from 5–10% up to 100% of nominal speed
- The BEMF must be high enough
- Based on the BEMF zero-crossing method
- Other advanced BEMF estimation techniques:
 - System observers
 - Measurement of a non-conductive phase with multi-sampling

The following sections discuss the concept of zero-crossing, as well as the methods and conditions for its correct evaluation.

3.2 Principles of six-step BLDC motor control

The three-phase BLDC motor is operated in a two-phase model; that is, the two phases that produce the highest torque are energized while the third phase is off. Which two phases are energized depends on the rotor position. The energized phases change every 60° (electrical degrees) as shown in [Figure 1](#). The figure also shows ideal BEMF waveforms. The third phase can be used to observe the BEMF voltage to recognize the correct commutation event, as described later. Current commutation is done by a six-step inverter as shown in the simplified form in [Figure 2](#). [Figure 1](#) and [Table 1](#) show the switching sequence and current direction.

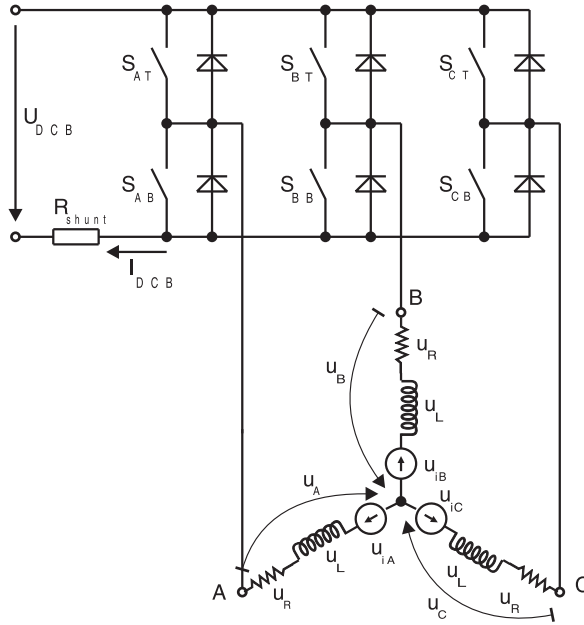

Figure 2. Power stage and motor topology

Table 1. Six-step switching sequence

Rotor position	Sector number	Switch closed	Phase current		
			A	B	C
0–60°	1	S _{AT} S _{BB}	+	–	off
60–120°	2	S _{AT} S _{CB}	+	off	–
120–180°	3	S _{BT} S _{CB}	off	+	–
180–240°	4	S _{BT} S _{AB}	–	+	off
240–300°	5	S _{CT} S _{AB}	–	off	+
300–360°	6	S _{CT} S _{BB}	off	–	+

To explain and simulate the idea of BEMF sensing techniques, this document provides a simplified mathematical model founded on the basic circuit topology (see Figure 2). The voltage for a three-phase BLDC motor is supplied by a typical three-phase power stage designed using IGBT or MOSFET switches. The power stage switches are controlled by the MCU’s on-chip FlexPWM module, which creates the desired control patterns. The goal of the model is to find out the dependency between the motor characteristics and switching angle. The switching angle is the angular difference between a real switching event and the ideal one. The motor drive model consists of a three-phase power stage and a BLDC motor. The power for the system is provided by a DC bus voltage source U_{DCB} . Six semiconductor switches ($S_{A/B/C/T/B}$) deliver the rectangular voltage waveforms to the motor (see Figure 1). The semiconductor switches and diodes are simulated as ideal devices. The natural voltage level of the whole model is referenced to half of the DC bus voltage, which simplifies the mathematical expressions.

3.2.1 BEMF zero-crossing detection

Figure 1 shows the motor phase winding voltage waveforms for the right commutation. As we can see, the right commutation event should be in the middle of two BEMF zero-crossings. So, the BEMF zero-crossing signal can simply be used as a rotor position feedback to estimate the right commutation time point.

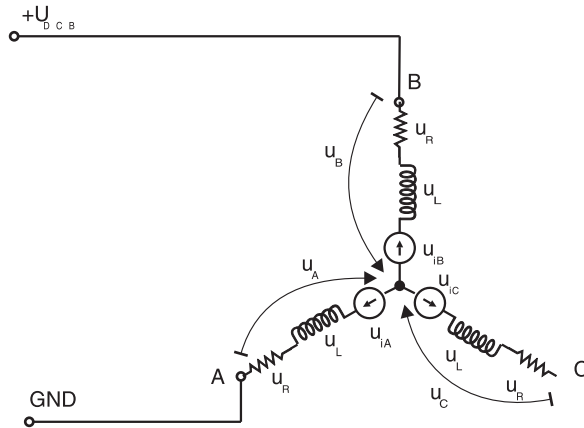

Figure 3. Zero-crossing detection and commutation diagram

The e_{1x} signals in Figure 1 are the BEMF voltages. These are the U_{iX} voltages in Figure 3.

This technique is established on the fact that only two phases of a motor are energized and third non-fed phase can be used to sense the BEMF voltage.

The following conditions are met:

$$S_{Ab}, S_{Bt} \leftarrow PWMswitching$$

$$u_N = u_{DCB} - ri - L \frac{di}{dt} - u_{iB}$$

$$u_N = ri + L \frac{di}{dt} - u_{iA}$$

$$u_N = \frac{u_{DCB}}{2} - \frac{u_{iB} + u_{iA}}{2}$$

Eqn. 1

The voltage u_C can be calculated:

$$u_{iA} + u_{iB} + u_{iC} = 0$$

$$u_N = \frac{u_{DCB}}{2} + \frac{u_C}{2}$$

$$u_C = u_N + u_{iC}$$

$$u_C = \frac{3}{2}u_{iC} + \frac{u_{DCB}}{2} \tag{Eqn. 2}$$

The voltage u_{iC} is null at zero-crossing, so the resultant form is:

$$u_C = \frac{u_{DCB}}{2} \tag{Eqn. 3}$$

3.2.1.1 BEMF measurement

Figure 4 and Figure 5 show the BEMF sensing circuit which is realized on the power stage and controller board side. Each phase voltage is adjusted into the ADC converter range as is shown in Figure 4. The user can set up the three-phase voltage input ranges easily by the divider ratio.

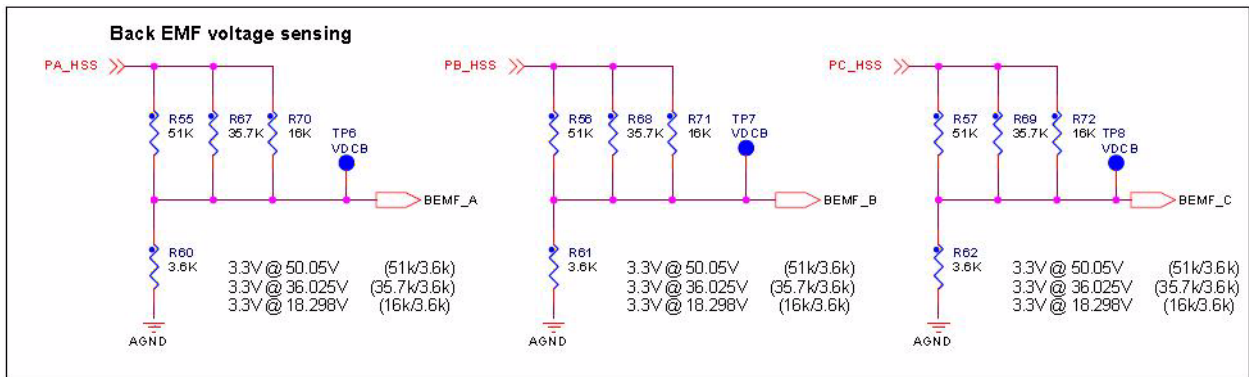

Figure 4. Back-EMF sensing circuit—dividers

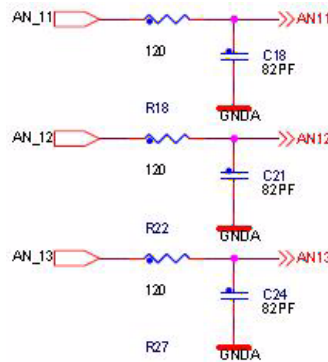

Figure 5. Back-EMF sensing circuit—low pass filters

3.3 States of BLDC drive

In order to start and run the BLDC motor, the control algorithm has to go through the following states:

- Alignment (initial position setting)
- Start-up (forced commutation)
- Run (sensorless running with BEMF acquisition and zero-crossing detection)

3.3.1 Alignment

As mentioned previously, the main task for sensorless control of a BLDC motor is the position estimation. Before starting the motor, however, the rotor position is not known. The main aim of the alignment state is to align the rotor to a known position. This known position is necessary to start rotation in the proper direction and to generate a maximal torque during startup. During alignment, all three phases are powered. Phase A is connected to the positive DC bus voltage, and Phases B and C are connected to the negative DC bus voltage. The alignment time depends on the mechanical constant of the motor, including load, and also on the applied motor current. In this state, the motor current (torque) is controlled by the PI controller on every PWM reload event.

3.3.2 Start-up

In the start-up state, the motor commutation is controlled in an open-loop without any rotor position feedback. The commutation period is controlled with a linear open-loop starting ramp. The open-loop start should be a short state at a very low speed where the BEMF is too small, so the zero-crossing events cannot be reliably detected.

3.3.3 Run

The running sensorless mode includes the BEMF acquisition with zero-crossing detection for the commutation control. The motor speed is controlled using zero-crossing period feedback to the speed PI regulator. The motor current is measured and filtered during commutation event and used as feedback into the current controller. Its output limits the speed controller output to achieve the maximal motor current in the required range.

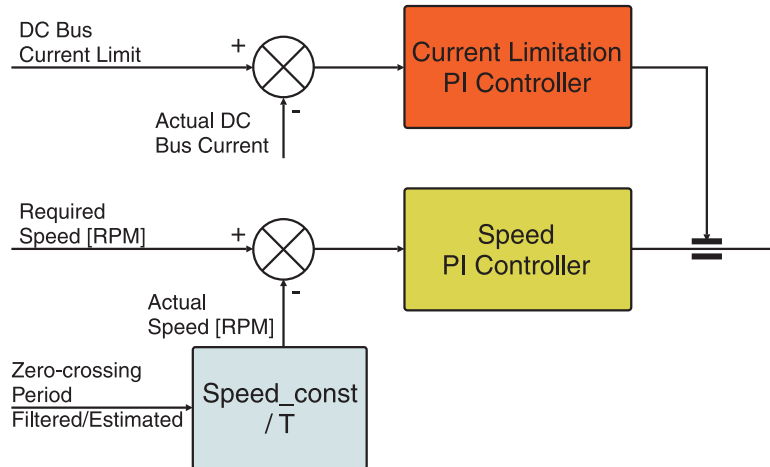

Figure 6. Speed control with torque limitation

4 MPC5604P controller board configuration

The BLDC sensorless application framework is designed to meet the following technical specification:

- MPC5604P controller board is used (refer to the dedicated user manual for the MPC5604P controller board)
- Three-phase low voltage power stage with an MC33937 pre-driver is used
- PWM output frequency = 20 kHz
- Current loop sampling period 50 us
- Speed loop sampling period 2.5 ms
- Three-phase BEMF voltage measurement using three dividers each per inverter leg. Phase voltage is routed to ADC0 and ADC1 as follows:
 - Phase A BEMF: ADC0/1—CH11
 - Phase B BEMF: ADC0/1—CH12
 - Phase C BEMF: ADC0/1—CH13
- DC bus voltage measurement routed to ADC1 as follows:
 - DC bus voltage: ADC1—CH0
- DC bus current measurement routed to ADC1 as follows:
 - DC bus current: ADC1—CH2

The MPC5604P device includes special modules (FlexPWM, CTU, ADC, and eTIMER) dedicated for motor control applications. These modules are directly interconnected and can be set-up in-line with any type of application or requirements. [Figure 7](#) shows module interconnection. The modules are described below and a detailed description can be found in the MPC5604P reference manual.

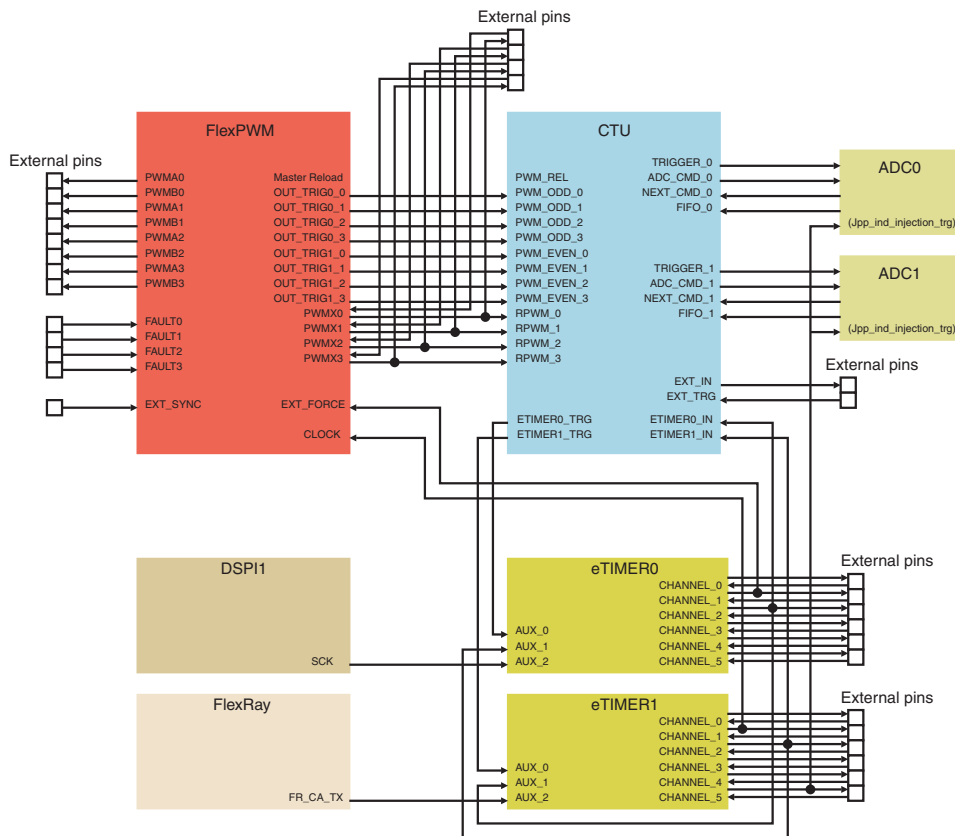

Figure 7. MPC5604P motor control peripherals modules connection

4.1 FlexPWM

The MPC5604P device includes two PLLs. PLL1 is used to generate the motor clock time domain of 120MHz. The Clock Generation Module generates the reference clock MC_PLL_CLK for all the motor control modules (FlexPWM, CTU, ADC0 and 1, eTimer0 and 1).

The FlexPWM sub-module 0 is configured to run as a master and to generate the Master Reload Signal (MRS) and counter synchronization signal (master sync) for other submodules. The MRS signal is generated at every occurrence of sub-module 0, VAL1 compare, that is, a full cycle reload. All double buffered registers are updated on occurrence of a MRS, therefore, the update of a new PWM duty cycles is done every PWM periods.

The application uses center-aligned PWMs. The VAL0 register defines the centre of the period and is set to zero and the INIT register to the negative value of VAL1. Suppose that the PWM clock frequency is 120MHz, the required PWM output 20kHz, then the VAL1, VAL0 and INIT registers are set as follows:

- $VAL1 = (120000000 \div 20000) \div 2 = 3000 = 0x0BB8_{hex}$
- $VAL0 = 0$
- $INIT = -VAL1 = -3000 = 0xF448_{hex}$

The duty cycle is given by setting the value of the registers VAL2 and VAL3. The VAL2 register value is the negative of VAL3.

MPC5604P controller board configuration

- $VAL3 = (DC \times PERIOD) \div 2 = (0.1 \times 6000) \div 2 = 300 = 0x012C_{hex}$
- $VAL2 = -VAL3 = -300 = 0xFED4_{hex}$

4.2 CTU

The Cross Triggering Unit (CTU) works in triggered mode. The MRS from the flexPWM submodule0 is selected from the Input Selection Register (TGSISR) to reload the TGS Counter register with the value of the TGS Counter Reload Register (TGSCRR). The TGS is able to generate up to eight events. Each trigger can be delayed from an MRS occurrence, the delay is set in the TGS Compare registers.

The MRS signal is generated every PWM period, the counter can count up to 6000_{DEC} , the INIT value is zero.

The application uses only one trigger event for measuring the BEMF, DC bus voltage, and DC bus current.

- $T0CR = 180_{DEC}$

The T0CR value is set up with respect to the real delays in the system as shown. The minimal delay value is given by the dead-time value for a rising edge, the power transistor turn-on delay, the rise time and settling time of the BEMF RC filter.

The CTU Scheduler subUnit (SU) generates the trigger event according to the occurred trigger event. The following trigger event is generated:

- ADC command output

T0CR generates an ADC command event output, with the command offset initially set to two. This is used as the synchronization signal to the ADC (ADC commands 2–13 for BEMF voltages, DC bus voltage and DC bus current measurement)

ADC Command List								
	First command	Command Interrupt	Conversion Mode	ADC Module	ADC Channel	ADC A Channel	ADC B Channel	FIFO
ADC Command 0	<input type="checkbox"/>	<input type="checkbox"/>	single	A	0			0
ADC Command 1	<input type="checkbox"/>	<input type="checkbox"/>	single	A	0			0
ADC Command 2	<input checked="" type="checkbox"/>	<input type="checkbox"/>	dual			13	0	0
ADC Command 3	<input type="checkbox"/>	<input checked="" type="checkbox"/>	dual			0	2	0
ADC Command 4	<input checked="" type="checkbox"/>	<input type="checkbox"/>	dual			12	0	0
ADC Command 5	<input type="checkbox"/>	<input checked="" type="checkbox"/>	dual			0	2	0
ADC Command 6	<input checked="" type="checkbox"/>	<input type="checkbox"/>	dual			11	0	0
ADC Command 7	<input type="checkbox"/>	<input checked="" type="checkbox"/>	dual			0	2	0
ADC Command 8	<input checked="" type="checkbox"/>	<input type="checkbox"/>	dual			13	0	0
ADC Command 9	<input type="checkbox"/>	<input checked="" type="checkbox"/>	dual			0	2	0
ADC Command 10	<input checked="" type="checkbox"/>	<input type="checkbox"/>	dual			12	0	0
ADC Command 11	<input type="checkbox"/>	<input checked="" type="checkbox"/>	dual			0	2	0
ADC Command 12	<input checked="" type="checkbox"/>	<input type="checkbox"/>	dual			11	0	0
ADC Command 13	<input type="checkbox"/>	<input checked="" type="checkbox"/>	dual			0	2	0
ADC Command 14	<input checked="" type="checkbox"/>	<input type="checkbox"/>	dual			11	0	0
ADC Command 15	<input type="checkbox"/>	<input type="checkbox"/>	dual			12	1	0
ADC Command 16	<input type="checkbox"/>	<input type="checkbox"/>	dual			13	2	0
ADC Command 17	<input type="checkbox"/>	<input checked="" type="checkbox"/>	dual			14	3	0
ADC Command 18	<input type="checkbox"/>	<input type="checkbox"/>	single	A	0			0
ADC Command 19	<input type="checkbox"/>	<input type="checkbox"/>	single	A	0			0
ADC Command 20	<input type="checkbox"/>	<input type="checkbox"/>	single	A	0			0
ADC Command 21	<input type="checkbox"/>	<input type="checkbox"/>	single	A	0			0
ADC Command 22	<input type="checkbox"/>	<input type="checkbox"/>	single	A	0			0
ADC Command 23	<input type="checkbox"/>	<input type="checkbox"/>	single	A	0			0

Figure 8. CTU ADC Command List configuration

The ADC Commands List Control Register (CLCRx) sets the assignment to an ADC command or to a stream of commands. The index pointer to the ADC command list, T0_INDEX, is updated according to the sector in which the actual commutation step resides, calculated by the actual zero-cross event of the six-step control algorithm. There are six sectors within the output voltage hexagon of the inverter per one electrical revolution, therefore you have a six different ADC commands. In each sector, ADC0/1 converts the BEMF voltage, DC bus voltage and DC bus current.

4.3 eTIMER

The eTimer module0.channel 1 generates, through OFLAG output, a forced signal for the FlexPWM module, which changes the PWM output with regards to the new motor commutation state, as shown in Figure 7. The time base for the counter is derived from MC_PLL_CLK. The prescaler register divides the MC_PLL_CLK by 128. The time base for commutation events is:

$$f_{COMM} = (120000000 \div 128) = 937500 \text{ Hz}$$

The value of the COMP1 register defines the time of the next commutation event. The eTimer output (OFLAG) is set at the compare occurrence, and generates an external forced signal for the FlexPWM

module. The external forced signal updates the PWM outputs in-step with the preloaded state according to the newly applied sector pattern.

5 Software implementation

5.1 Introduction

This section describes the software design of the BLDC sensorless algorithm. The [Figure 9](#) shows the application block diagram.

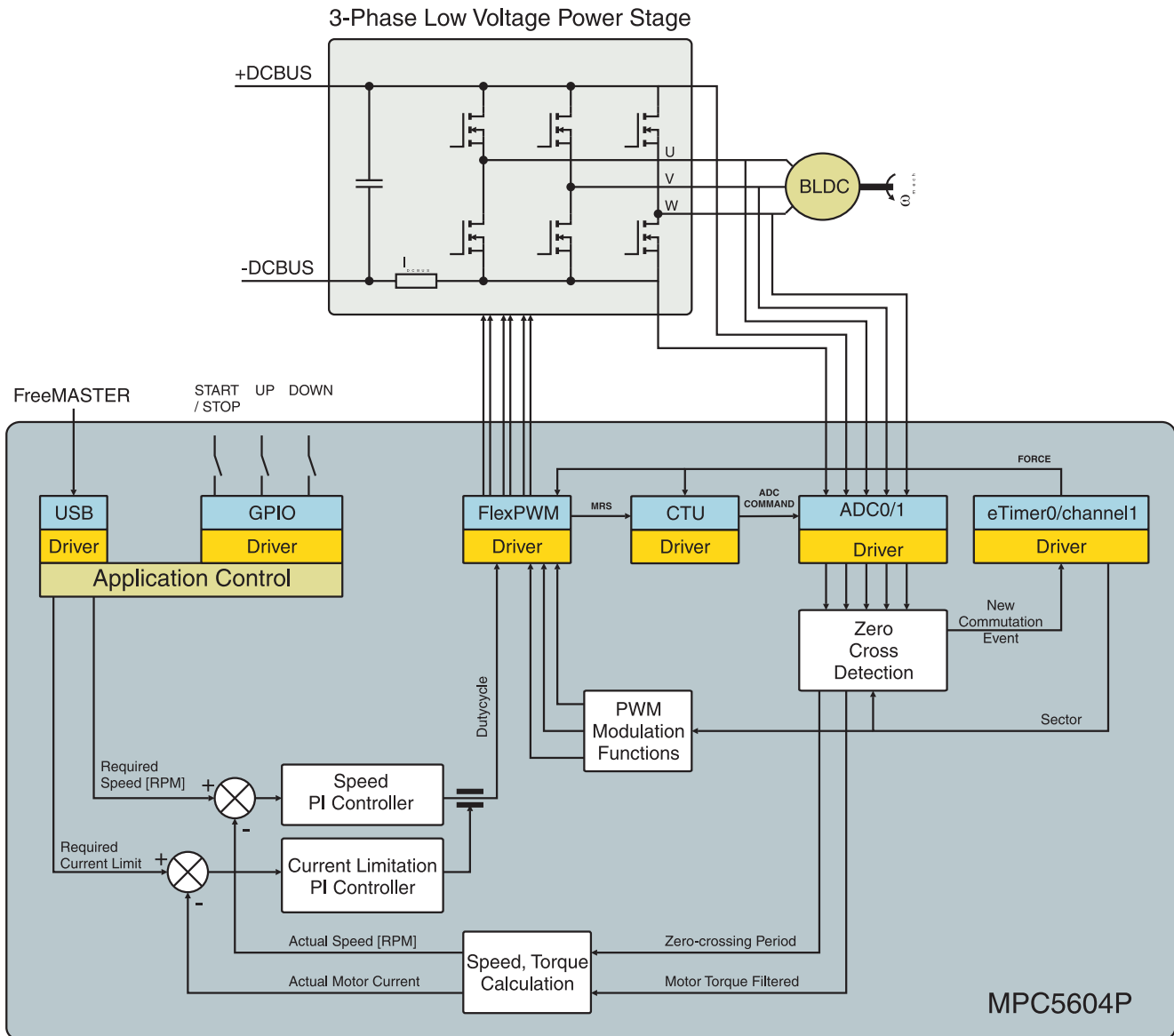

Figure 9. System block diagram

The application is optimized for using MPC5604P motor control peripherals to achieve small core impact. The motor control peripherals (FlexPWM, CTU, eTimer, ADC modules) are internally linked/set up together to work independently from the core and to achieve deterministic sampling of analogue quantities and precise commutation of the stator field. The software part of the application consists of different blocks which will be described below. The entire application behavior is scalable by the FreeMASTER tool from a PC.

5.2 Application flow

The application is interrupt driven running in real time. The main tasks of the motor control application are periodically running in one interrupt service routine, driven by the CTU-ADC command interrupt request every 50us. This includes both the fast current and slower speed control loops. The commutation of the motor stator flux is provided in the second interrupt service routine driven by an eTimer0.Channel 1 interrupt event. All tasks apart from the commutation function are executed in order, as described in the application state machine shown in [Figure 12](#), and the application flow charts [Figure 10](#) and [Figure 11](#).

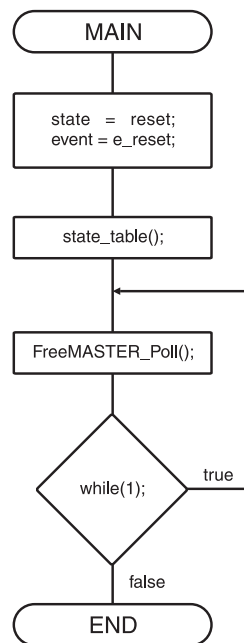

Figure 10. Main task flow

This type of application requires precise and deterministic sampling of analogue quantities, and to execute all motor control functions the state machine routines are called within a periodic interrupt routine. In reference to the state machine, the interrupt has to be set-up and allowed at the end of the RESET state, where all peripheral settings also have to be done. Consequently, the RESET state is called before the main loop, as shown in [Figure 10](#). The background loop handles non-critical tasks, such as the FreeMASTER communication polling and the MOSFET pre-driver fault service routine.

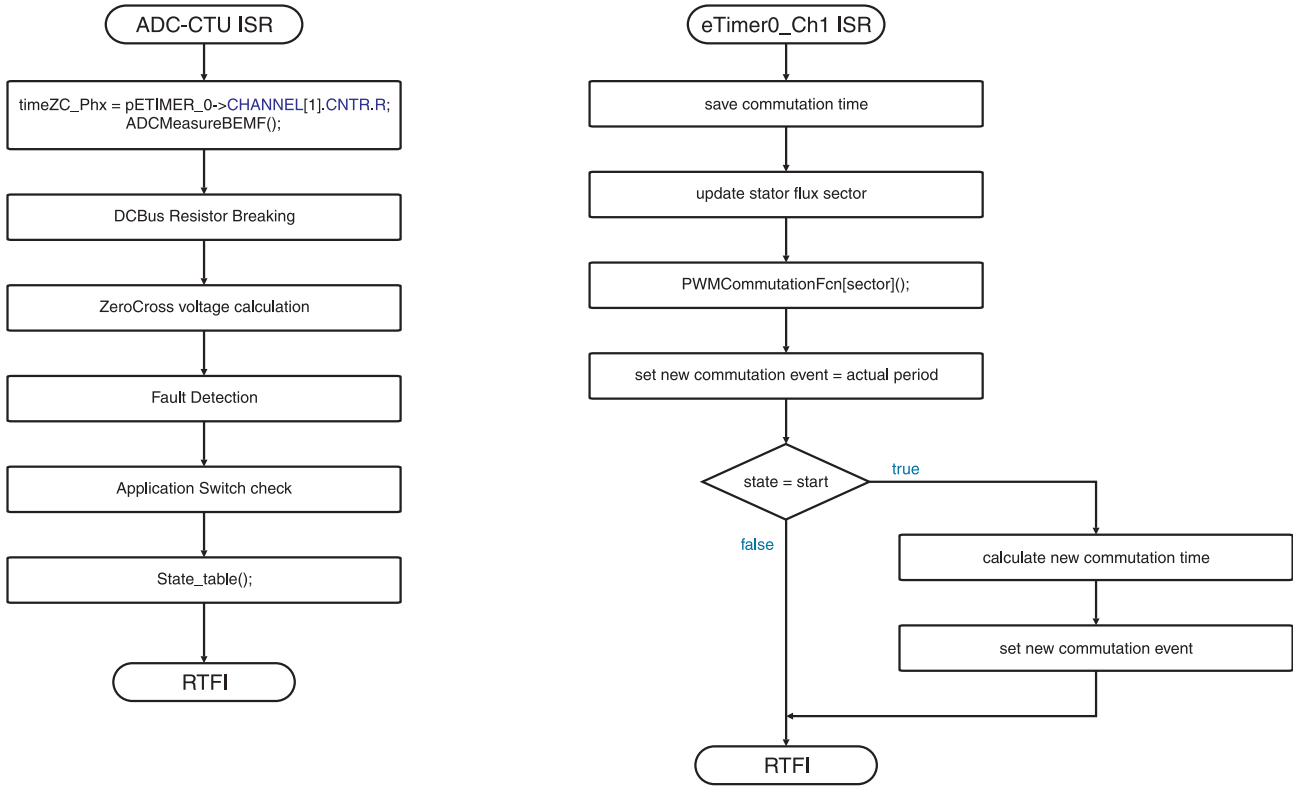

Figure 11. CTU-ADC ISR routine flow chart

5.3 Speed evaluation and control

The application uses eTIMER0.channel1 to achieve a precise commutation of a BLDC motor as described below.

When the zero-cross event is recognized the eTimer0.channel1.COMP1 register is filled by a new calculated value of the next commutation time. When a counter matches the COMP1 register value, the OFLAG signal forces the flexPWM module with a new set-up without any delay or CPU load.

5.3.1 Speed evaluation

The speed is calculated in the Slow Control Loop which is part of the *BLDC_Fast_ISR* routine. The zero-cross detection algorithm provides the actual commutation period duration for each commutation event. These variables are referred to the eTIMER0.channel1. The eTIMER0.channel1 clock is set up to 937500 Hz. So, to calculate the real time commutation period, we can write:

$$T_{REAL} = T \times T_{CLK} \tag{Eqn. 4}$$

$$T_{CLK} = \frac{1}{f_{CLK}} \tag{Eqn. 5}$$

$$T_{REAL} = \frac{T}{f_{CLK}} \quad \text{Eqn. 6}$$

where:

- T_{REAL} is the real commutation period
- T_{CLK} is the period of the eTIMER0.channel1
- T is the value measured in the eTIMER0.channel1 increments
- f_{CLK} is the eTIMER0.channel1 clock rate

If we know the commutation period, we can calculate the period of one electrical revolution:

$$T_{elrev} = T_{REAL} \times N = \frac{T \times N}{f_{CLK}} \quad \text{Eqn. 7}$$

where:

- T_{ELREV} is the real period of one electrical revolution
- N is number of commutations in one electrical period

To calculate the period of one mechanical revolution, the result of [Equation 7](#) must be multiplied by the number of pole pairs:

$$T_{mechrev} = T_{elrev} \times p = \frac{T \times N \times p}{f_{CLK}} \quad \text{Eqn. 8}$$

and finally we can calculate the mechanical speed in revolutions per minute:

$$\omega_{mech} = \frac{60}{T_{mechrev}} = \frac{60 \times f_{CLK}}{T \times N \times p} \quad \text{Eqn. 9}$$

If the clock rate is 937500Hz, the number of commutations per electrical revolution is 6, and the number of pole-pairs is 4, we can get the constant:

$$c = \frac{60 \times f_{CLK}}{N \times p} \quad \text{Eqn. 10}$$

Therefore, the speed is calculated as:

$$\omega_{mech} = \frac{c}{T} \quad \text{Eqn. 11}$$

where c is the mechanical speed constant, that is 14.0625×10^6 .

To achieve a better resolution, the mechanical speed is multiplied by 1000.

5.3.2 Speed controller

The motor speed PI controller is called in every speed control loop, which is slower than the current control loop. The K_p and K_i constants are calculated from either the motor or the whole mechanical system

parameters. The speed loop bandwidth was chosen as 20Hz and attenuation as 1. Unfortunately, the parameters of the LINIX motor were unknown prior the test, therefore the constants of the PI controller have been set experimentally.

5.4 Zero-cross detection

The zero-cross algorithm is executed in each *BLDC_Fast_ISR* routine. The CTU module triggers stator flux sector related analogue quantities, such as the actual DC-BUS and related phase BEMF voltage, the DC bus current, and time of measurement. [Figure 1](#) shows the behavior of the BEMF voltage for each sector. The relevant zero-cross function is called with respect to the actual stator flux sector.

The zero-cross event occurs when the phase BEMF voltage crosses the $U_{DCBUS} \div 2$, and basically it is half of the actual commutation period. When this occurs, the next commutation event is calculated from actual zero-cross time and actual zero-cross period. The result is loaded into the eTimer0.channel1 compare register to achieve precise commutation of the stator flux. The algorithm also stores the motor current and the actual zero-cross period. These values are used for speed and motor current calculations.

5.5 Current limitation controller

The motor current limitation controller is called in every fast control loop. The parameters of the armature current PI controller are calculated assuming the armature current loop bandwidth and attenuation and motor physical constants.

5.6 State machine

The application state machine is implemented using a two-dimensional array of pointers to a function variable called `state_table[][]()`, with the first parameter describing the current application event and the second parameter describing the actual application state. These two parameters select a particular pointer to a state machine function, which causes a function call whenever `state_table[][]()` is called.

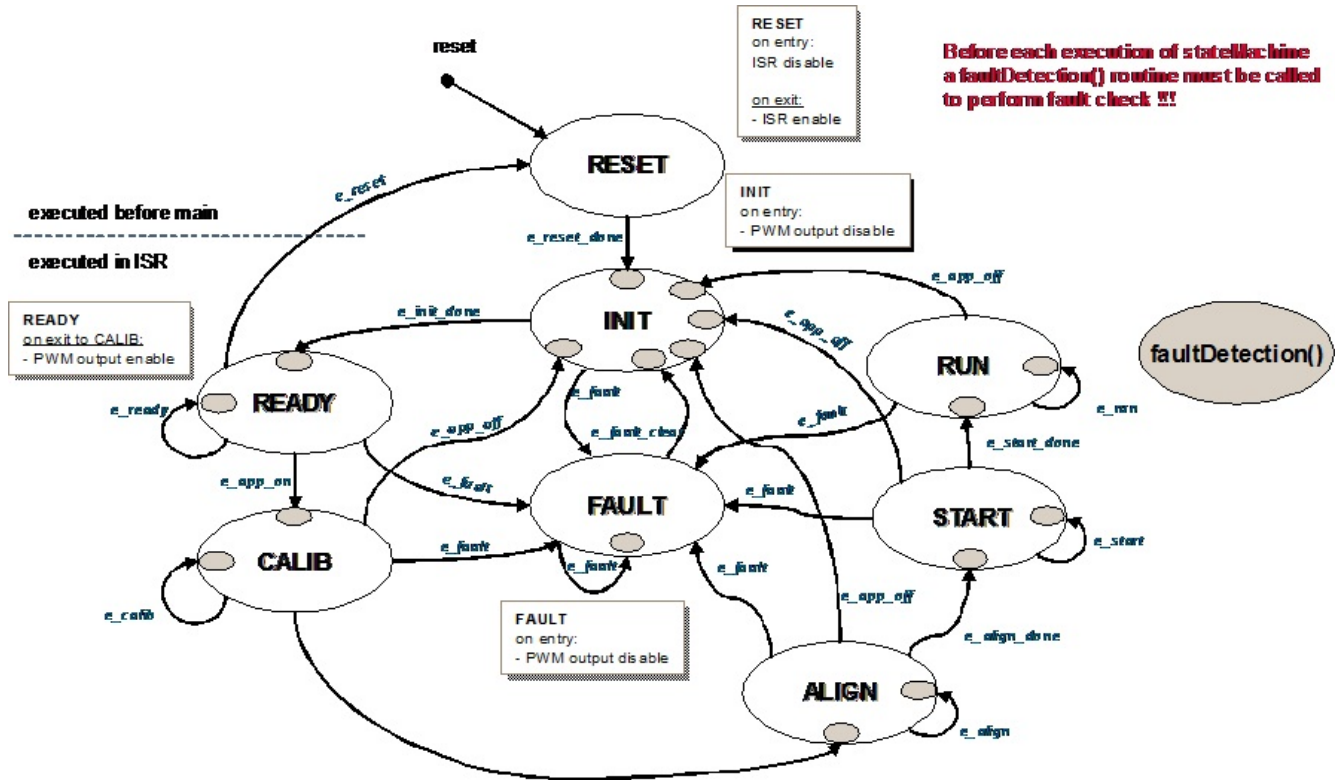

Figure 12. Application state machine

The application state machine consists of the following eight states, selected using the variable `state` defined as `AppStates`:

- RESET state = 0
- INIT state = 1
- FAULT state = 2
- READY state = 3
- CALIB state = 4
- ALIGN state = 5
- RUN state = 6
- START state = 7

To signalize/initiate a change of the state, the fifteen application events are defined and selected using the variable `event` defined as `AppEvents`:

- `e_reset` - event = 0
- `e_reset_done` - event = 1
- `e_fault` - event = 2
- `e_fault_clear` - event = 3
- `e_init_done` - event = 4
- `e_ready` - event = 5

Software implementation

- e_app_on - event = 6
- e_calib - event = 7
- e_calib_done - event = 8
- e_align - event = 9
- e_align_done - event = 10
- e_run - event = 11
- e_app_off - event = 12
- e_start - event = 13
- e_start_done - event = 14

5.6.1 RESET state

State RESET is the first state which is executed after the MCU exits the power on reset state and enters into the main() function. It is executed only once at the start of the main function to provide system variables and all peripherals settings. Before configuring all peripherals, all interrupts are disabled and enabled at the RESET state end, with respect to interrupt driven application as described before. This routine also includes initialization and setting of the MC33905 system basis chip which provides the power supply for the MPC5604P controller board and the MC33937 MOSFET pre-driver. Both routines use SPI peripheral and must be called after the DSPI and SIU config routines.

5.6.2 INIT state

State INIT is similar to the RESET routine one pass routine, which allows users to set up application variables, and at the end the transition event is set to the READY state if there isn't any fault event. It is executed directly after the RESET state or after a RUN state when an application is stopped.

Transition to the FAULT state is performed automatically when a fault occurs.

Transition to the READY state is performed automatically at the end of the INIT routine.

5.6.3 FAULT state

The application goes to this state immediately when a fault is detected. The system allows all states to pass into the FAULT state by setting event=e_fault.

5.6.4 READY state

This state is used as an application initial state. The application only checks fault inputs and the application switch status to enable an application.

Transition to the RESET state is performed by setting the variable event to event=e_reset, which is done automatically when the user sets switchAppReset true using FreeMASTER.

Transition to the INIT state is performed by setting the variable event to event=e_app_on, which is done automatically on the rising edge of switchAppOnOff=true using FreeMASTER. Its value can also be changed by switching on the external switch on the MPC5604P controller board.

5.6.5 CALIB state

The CALIB state provides calibration of the analogue quantities used by the sensorless motor control algorithm. The analogue offsets are calibrated for all six voltage vectors applied to the three-phase bridge. When the calibration is done for all six sectors (voltage vectors), the alignmentTimer, svmsector and torqueRequired variables are initialized and the PWM_Alignment() function is called to set the PWM output. The variable event is set automatically to event=e_calib_done, this enables transition to the Alignment state.

Transition to the FAULT state is performed automatically when a fault occurs.

Transition to the INIT state is performed by setting the variable event to event=e_app_off, which is done automatically on the falling edge of switchAppOnOff=false using FreeMASTER, or a second way how to change its value is to switch off the external switch on the MPC5604P controller board.

5.6.6 ALIGN state

The ALIGN state provides the motor rotor alignment process as it has been shown in [Section 3.3.1, “Alignment.”](#) The user can set up the variable ALIGNMENT_TIME and the propriety motor current depending on the minimal mechanical system behavior (mechanical system inertia, motor time constants, and so on) time to assure the correct motor rotor position. The alignment current is controlled via the PI regulator, updated every PWM cycle. The required alignment current can be adjusted by the torqueRequired variable. When the counter alignmentTimer reaches zero, switchAlignDone is set to true and variables used for the next state are initialized, and the variable event is automatically set to event=e_align_done. This enables transition to the START state.

Transition to the FAULT state is performed automatically when a fault occurs.

Transition to the INIT state is performed by setting event to event=e_app_off, which is done automatically on the falling edge of switchAppOnOff=false using FreeMASTER or the second way how to change its value is to switch off the external switch on the MPC5604P controller board.

5.6.7 START state

The START state provides the start rotor rotation sequence as has been shown in [Section 3.3.2, “Start-up.”](#) The motor current PI controller function Ureq=GFLIB_ControllerPIpAW(torque_err, &i_controllerParams1) is called every PWM cycle. Its parameters (Proportional gain, Integral gain, Lower and Upper Limits) can be set in the i_controllerParams1 structure. The PI controller function is part of the MPC5604P Motor Control Library and its detailed description is shown in the MPC5604P_MCLib manual.

Transition to the FAULT state is performed automatically when a fault occurs.

Transition to the INIT state is performed by setting the variable event to event=e_app_off, which is done automatically on the falling edge of switchAppOnOff=false using FreeMASTER, or a second way to change its value is to switch off the external switch on the MPC5604P controller board.

5.6.8 RUN state

The RUN state provides the motor speed and current regulation sequence as it has been described in [Section 3.3.3, “Run.”](#) The zero-cross detection function `ZCdetection[svmSector]()` is called every PWM cycle to manage the correct motor commutation process. In the slow control loop performed every 1 msec, the speed and current control loops are performed.

Transition to the FAULT state is performed automatically when a fault occurs.

Transition to the INIT state is performed by setting the variable event to `event=e_app_off`, which is done automatically on the falling edge of `switchAppOnOff=false` using FreeMASTER. Its value may also be changed by switching off the external switch on the MPC5604P controller board.

5.7 Library functions

The application source code uses the new Freescale Motor Control Library for the MPC560xP family of microcontrollers, which can be found at www.freescale.com/AutoMCLib. The library contains three independent library blocks: GFLIB, GDFLIB, GMCLIB. GFLIB includes basic mathematical functions (such as sine, cosine, LUT, ramp, and so on). Advance filter functions are part of the General Digital Filters Library and standard motor control algorithms are part of the General Motor Control Library.

5.8 Setting the software parameters for a specific motor

The default software parameter settings have been calculated and tuned for a hardware setup with the LINIX 45ZWN24-90 motor.

All application parameters dedicated to the motor or application ratings (max. voltage, velocity, and so on) are defined in the *BLDC_appconfig.h* file and commented to help the user modify the parameters according to their own specific requirements.

All hardware-specific parameters dedicated to the hardware boards and processor (pin assignment, clock setting, peripheral settings, and so on) are defined in the *MPC5604P_appconfig.h* file.

6 FreeMASTER user interface

The FreeMASTER debugging tool is used to control the application and monitor variables during run time.

Communication with the host PC occurs via USB. However, because FreeMASTER supports RS232 communication, there must be a driver for the physical USB interface CP2102 installed on the host PC that creates a virtual COM port from the USB. The driver can be installed from www.silabs.com.

The application configures the LINflex module of the MPC5604P for a communication speed of 19200bps. Therefore, FreeMASTER also has to be set to this speed.

6.1 Application start

- Install the USB driver to create a virtual COM port for emulating RS232 communication (“CP210x USB to UART Bridge VCP Drivers” from Silicon Labs at the following link: <http://www.silabs.com/products/mcu/Pages/USBtoUARTBridgeVCPDrivers.aspx>)

- Connect a USB cable to the MPC5604P controller board and to the host PC
- Connect the power supply to the power-stage. The controller board is supplied from the power stage. The BLDC motor used is designed for 24V phase voltage.
- Start the FreeMASTER project located in
 \FreeMASTER_control\MPC5604P_SensorlessBLDC.pmp
- Enable communication by pressing the Stop button in the toolbar in FreeMASTER, or by pressing Ctrl + K
- Successful communication is signaled in the status bar. If communication isn't established, check the USB connection between the PC and the MPC5604P controller board and the communication port and speed. The communication port and speed can be set up in menu Project\Options (or by pressing Ctrl + T). The communication speed has to be set to 19200Bd.
- If no actual faults are present in the system, all LED-like indicators shall be dark red. If there is a fault present, identify the source of the fault and remove it. Successful removal is signaled by the switching off of the respective LED-like indicator.
- Click on the APP ON button or switch over the ON/OFF switch on the MPC5604P controller board to run the application. The BLDC motor starts running. You are able to change the mechanical speed by writing to the desiredSpeed variable.

7 Conclusion

The described design shows simplicity and efficiency in use of the MPC5604P microcontroller for BLDC motor control, and introduces it as an appropriate candidate for different low-cost applications in the automotive area.

8 References

Document number	Title	Location
MPC560XPRM	<i>MPC5604P Microcontroller Reference Manual</i>	www.freescale.com
MC33937	<i>Three Phase Field Effect Transistor Pre-driver Data Sheet</i>	
—	<i>3-phase BLDC Sensorless Motor Control Development Kit with MPC5604P</i>	www.freescale.com/ AutoMCDevKits
MPC5604PMCBUM	<i>MPC5604P Controller Board User Manual</i>	
3PHLVPSUM	<i>3-phase Low Voltage Power Stage</i>	
MCLIB_MPC560XP_V0.94_FIX_LIB	<i>Automotive Math and Motor Control Library Set for Qorivva MPC560xP with 32-bit fixed-point or single precision floating point arithmetic</i>	www.freescale.com/AutoMCLib
—	<i>FreeMASTER Run-Time Debugging Tool</i>	www.freescale.com/FREEMASTER

9 Revision history

Revision (Date)	Description
0 (02/2011)	Initial release.
0 ¹ (04/2012)	On the front page, added SafeAssure branding. On the front page, added Qorivva branding to title. On the back page, applied new back page format.
1 (05/2012)	In "Library functions" section, added link to the library product summary page.

¹ No substantive changes were made to the content of this document; therefore, the revision number was not incremented.

How to Reach Us:

Home Page:

freescale.com

Web Support:

freescale.com/support

Information in this document is provided solely to enable system and software implementers to use Freescale products. There are no express or implied copyright licenses granted hereunder to design or fabricate any integrated circuits based on the information in this document.

Freescale reserves the right to make changes without further notice to any products herein. Freescale makes no warranty, representation, or guarantee regarding the suitability of its products for any particular purpose, nor does Freescale assume any liability arising out of the application or use of any product or circuit, and specifically disclaims any and all liability, including without limitation consequential or incidental damages. "Typical" parameters that may be provided in Freescale data sheets and/or specifications can and do vary in different applications, and actual performance may vary over time. All operating parameters, including "typicals," must be validated for each customer application by customer's technical experts. Freescale does not convey any license under its patent rights nor the rights of others. Freescale sells products pursuant to standard terms and conditions of sale, which can be found at the following address: <http://www.reg.net/v2/webservices/Freescale/Docs/TermsandConditions.htm>

Freescale, the Freescale logo, Altivec, C-5, CodeTest, CodeWarrior, ColdFire, C-Ware, Energy Efficient Solutions logo, Kinetis, mobileGT, PowerQUICC, Processor Expert, QorIQ, Qorivva, StarCore, Symphony, and VortiQa are trademarks of Freescale Semiconductor, Inc., Reg. U.S. Pat. & Tm. Off. Airfast, BeeKit, BeeStack, ColdFire+, CoreNet, Flexis, MagniV, MXC, Platform in a Package, QorIQ Qonverge, QUICC Engine, Ready Play, SafeAssure, SMARTMOS, TurboLink, Vybrid, and Xtrinsic are trademarks of Freescale Semiconductor, Inc. All other product or service names are the property of their respective owners. The Power Architecture and Power.org word marks and the Power and Power.org logos and related marks are trademarks and service marks licensed by Power.org.

© 2012 Freescale Semiconductor, Inc.

Document Number: AN4268

Rev. 1

08/2012

